

**Index**



9.0

**Product description**



9.1

**Technical specifications**



9.2

**Mounting**



9.3

**Built-in valve**



9.4

**Accessories**



9.6

**Standard specification clauses**



9.7

**Maintenance**



9.8



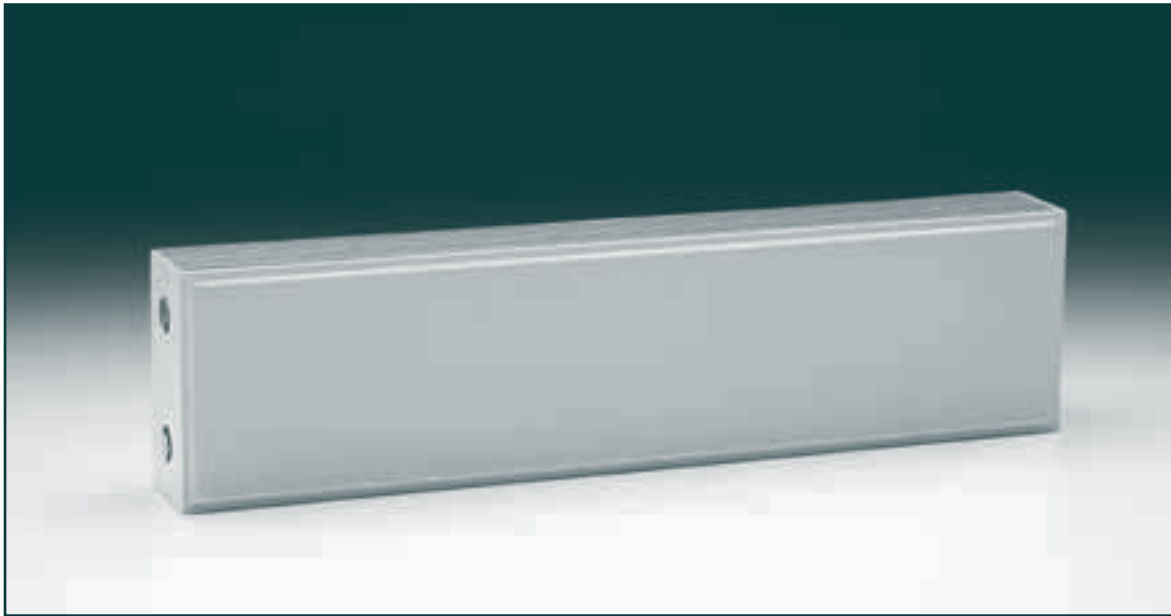
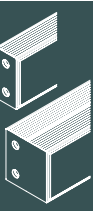

P200



9.0



9.1



9.2



9.3



9.4



9.6



9.7



9.8

## Features

- Low, streamlined design
- Member of the Plan® family
- Harmonious casing with integrated top grille
- Discreet appearance at either low or high level
- Ideal in front of glazing with optional feet and Plan back plate
- Flexible applications with single and double depths

## Product description

P200

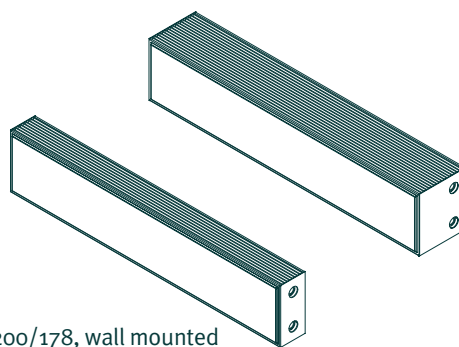

P200/98 and P200/178, wall mounted

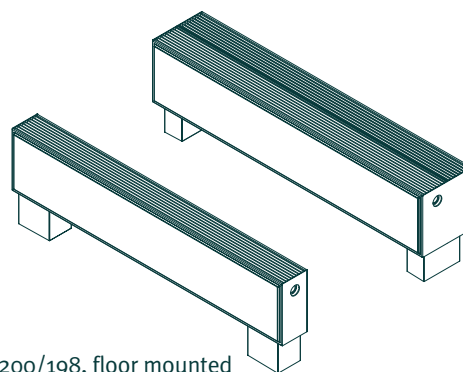

P200/105 and P200/198, floor mounted

### Description

Casing made from steel plate. Smooth rebated front plate, with closed ends. Integrated aluminium top grille. Internal flat tube heating element with welded on convector fins. P200 is available in single and double depths. P200 floor mounted is supplied with Plan back plate.

### Material

Casing: 2.00 mm steel to EN 10051  
Heating element: 70 mm x 11 mm x 2 mm flat tube to DIN 2395  
Convactor fins: 0.5 mm steel DIN 1623 and EN 10130  
Top grille: Anodised aluminium

### Test pressure

13 bar

### Max. operating pressure

10 bar in accordance with EN 442

### Max. operating temperature

90°C

### Surface treatment

Pretreatment:

- Degreasing and iron-phosphating

Priming:

- Primed with water based paint in pale grey

Paint finish:

- White RAL 9010: Powder PE, gloss approx. 50%
- Other colours: Powder painted as above or wet painted with high degree of total solids, gloss approx. 50%
- Surface treatment in accordance with DIN 55900 and EN 442

### Output

See output tables, page 9.2.1

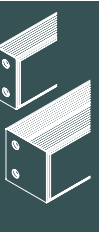

Fig. 9.1.1  
Height and length



Fig. 9.1.2  
P200/98\*

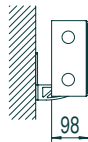

Fig. 9.1.3  
P200/178\*

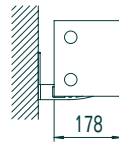

Fig. 9.1.4  
P200/105\*



Fig. 9.1.5  
P200/198\*



\* Profil

<b>Length</b>	610-2510 mm in increments of 100 mm
<b>Height</b>	200 mm
<b>Depth</b>	Wall mounted: 98 and 178 mm (see fig. 9.1.2 and 9.1.3) Floor mounted: 105 and 198 mm (see fig. 9.1.4 and 9.1.5)
<b>Tappings</b>	Tappings: 1/2" standard, adapter for 3/4" see page 9.2.1
<b>Mounting</b>	Wall or floor mounted, see pages 9.3.1 - 9.3.8 Brackets or feet included, see page 9.3.3 and 9.3.7 Air vent is supplied, see page 9.6.1 <b>NOTE:</b> P200 for floor mounting is supplied with Plan back plate.
<b>Colour</b>	Radiator: Powder coated in white RAL 9010 Top grille: Natural anodised aluminium  Radiator: Painted in other RAL and BS colours Top grille: Same colour as radiator
<b>Packing</b>	Packed securely in environmentally friendly materials.
<b>Optional extras</b>	<ul style="list-style-type: none"> <li>Built-in valve only available with underside connections (E, F, 2E, 2F), see pages 9.4.1 - 5</li> </ul>

**VARIANT**



9.0



9.1



9.2



9.3



9.4



9.6



9.7



9.8

# Technical specifications

P200

## Output

Table 9.2.1

P200 Model	Depth mm	Output		Water litres/ metre	Weight		
		W/metre 75/65-20	W/metre 90/70-20		kg/ metre	KM	n
P200/98	98	606	750	1.8	19.4	5.20	1.21
P200/178	178	1041	1304	2.7	29.0	6.96	1.27
P200/105	105	606	750	1.8	22.5	5.20	1.21
P200/198	198	1041	1304	2.7	33.2	6.96	1.27

## Tapping designation



P200/98 with side tapings

P200 models can be supplied with side or underside tapings.

Fig. 9.2.2  
Tapping designation, A, B, C, D, front view



Fig. 9.2.3  
Tapping designation, E, F, front view



Fig. 9.2.4  
Tapping designation, 2E and 2F, front view





### Water resistance

Water resistance can be calculated as:

**Example: P200/98**

Radiator depth:	98 mm
Radiator length:	2010 mm
Tappings:	1/2" A, D
Flow temperature $t_f$ :	75°C
Return temperature $t_r$ :	65°C
Output at 75/65-20°C, Q:	1212 Watt

Water flow:

$$\frac{Q}{(t_f - t_r) \times 1,163} =$$

$$\frac{1212}{10 \times 1,163} \sim 104.2 \text{ l/h}$$

Fig. 9.2.5

Water resistance - please contact Hudevad



9.0



9.1



9.2



9.3



9.4



9.6



9.7



9.8

# Mounting

P200

## Wall mounted, tapping designation, P200/98

### Sizes

Flow and return: 1/2"

### Position

P200/98, wall mounted, front view:

Fig. 9.3.1  
A-B-C-D side tapings

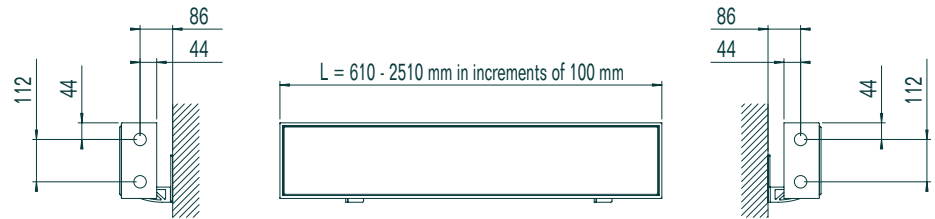

Fig. 9.3.2  
E-F/F-E bottom tapings

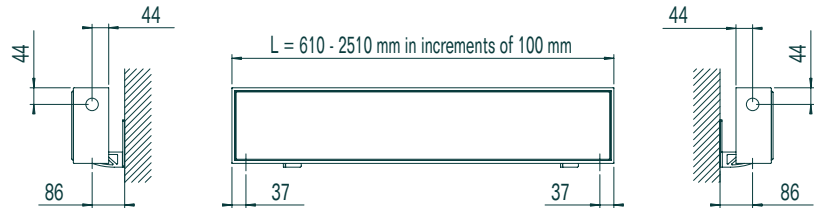
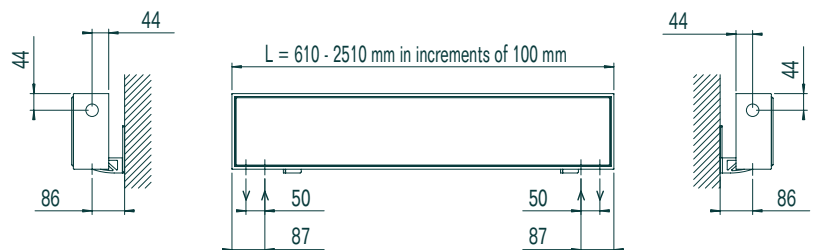

Fig. 9.3.3  
2E and 2F tapings



9.0

9.1

9.2

9.3

9.4

9.6

9.7

9.8

9.3.1

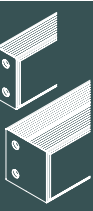

## Wall mounted, tapping designation, P200/178

**Sizes** Flow and return: 1/2"

**Position** P200/178, wall mounted, front view:

Fig. 9.3.4  
A-B-C-D side tapplings

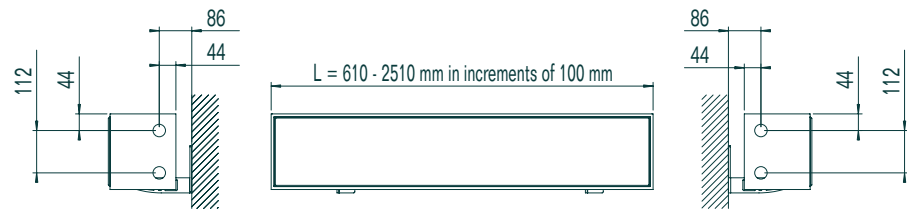

Fig. 9.3.5  
E-F/F-E bottom tapplings

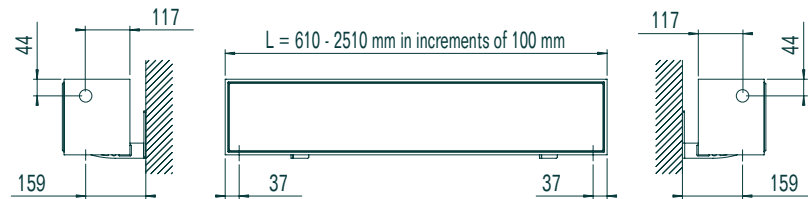
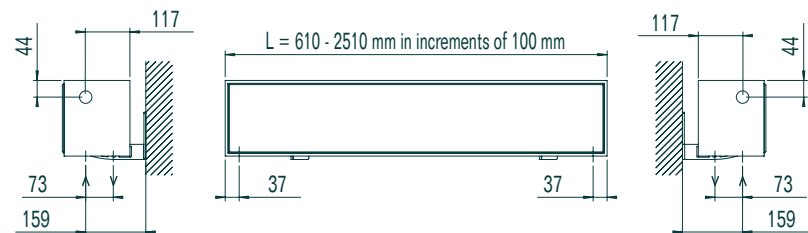

Fig. 9.3.6  
2E and 2F tapplings



9.0



9.1



9.2



9.3



9.4



9.6



9.7



9.8

# Mounting

## P200

### Bracket LK

#### Accessory for

P200. The bracket is available in two types to match the two radiator depths. Supplied unless otherwise specified.

#### Construction

Bracket types made in 5 mm steel plate, powder coated in RAL 9010. Coach screws, wall plugs and washers are included.

Fig. 9.3.7  
Bracket LK for P200/98

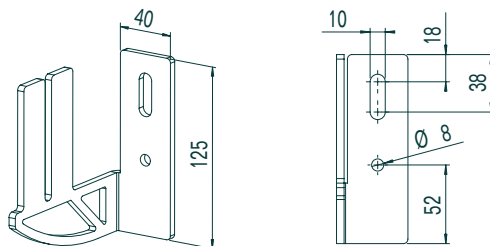
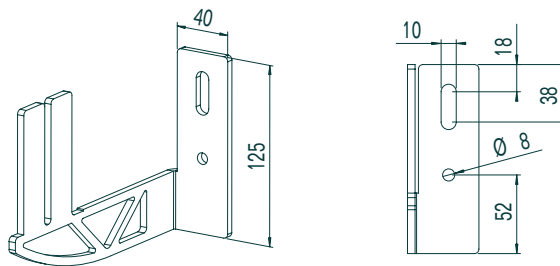

Fig. 9.3.8  
Bracket LK for P200/178



9.0

9.1

9.2

9.3

9.4

9.6

9.7

9.8

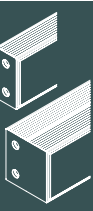

### Dimensions

Fig. 9.3.9  
P200/98 and 178. Tappings A-B-C-D.

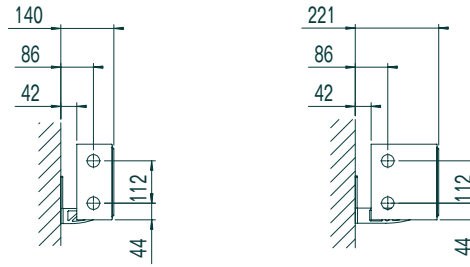

Fig. 9.3.10  
P200/98 and 178. Tappings E-F/F-E.

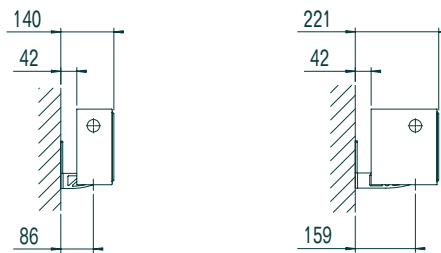

Fig. 9.3.11  
P200/98 and 178. Tapping 2E/2F and 2F/2E.

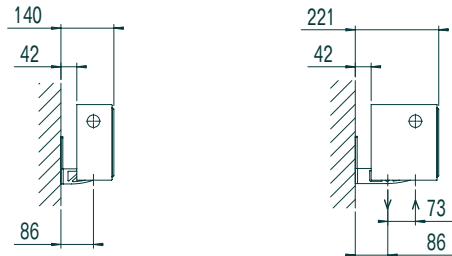

Fig. 9.3.12  
Position of rails, rear view

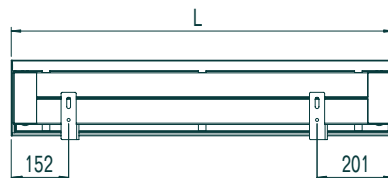

Table 9.3.13  
No. of brackets

	No. of brackets	
	Radiator length 610 - 2010 mm	Radiator length 2110 - 2510 mm
P200/98	2	3
P200/178	2	3



9.0



9.1



9.2



9.3



9.4



9.6



9.7



9.8

### Floor mounted, tapping designation, P200/105

**Sizes** Flow and return: 1/2"

**Position** P200/105, floor mounted, front view:

Fig. 9.3.14  
A-B-C-D tappings

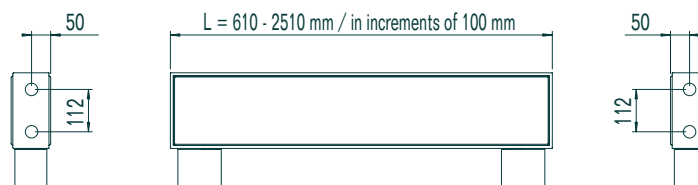

Fig. 9.3.15  
E-F/F-E tappings

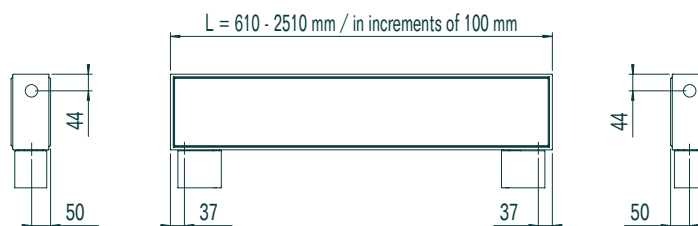
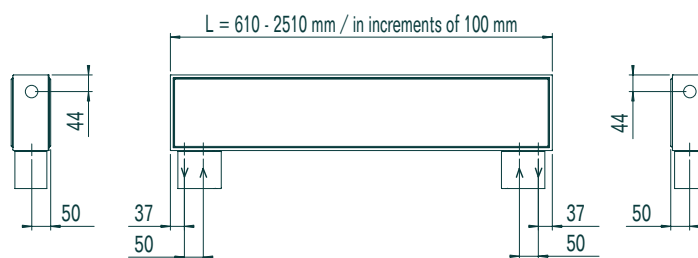

Fig. 9.3.16  
2E/2F tappings



9.0

9.1

9.2

9.3

9.4

9.6

9.7

9.8

9.3.5

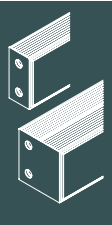

**Floor mounted,  
tapping designation, P200/198**

**Sizes** Flow and return: 1/2"

**Position** P200/198, floor mounted, front view:

Fig. 9.3.17  
A-B-C-D tappings

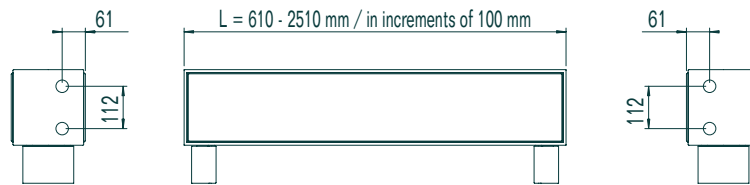

Fig. 9.3.18  
E-F/F-E tappings

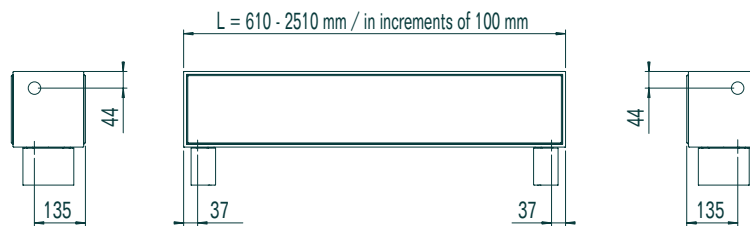
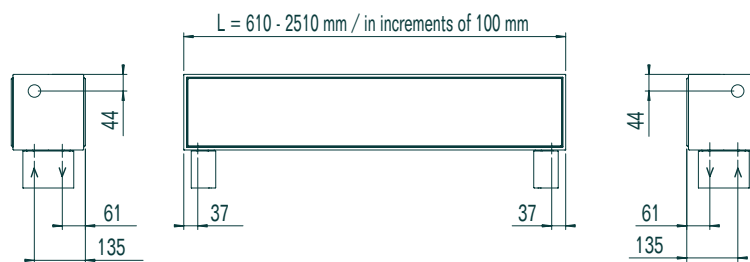

Fig. 9.3.19  
2E/2F tappings



9.0



9.1



9.2



9.3



9.4



9.6



9.7



9.8

## Mounting

P200

### FDC feet

#### Accessory for

P200/105 and P200/198

#### Application

For use where wall mounting is not possible, e.g in front of glazing

#### Construction

Closed rectangular bolted feet in 2 mm steel, with detachable cover. Mounted to floor with coach screws. all necessary parts and screws are supplied unless otherwise specified

**NOTE:** Allows underside connections to be concealed within foot.

Fig. 9.3.20

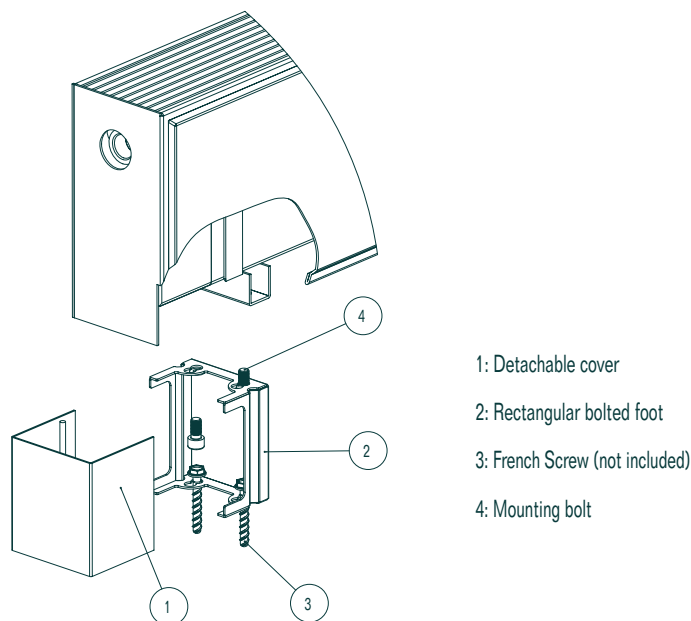

#### Height

P200 can be supplied with feet in standard heights of 100, 120 or 150 mm. For other heights, please contact Hudevad.

#### Monting

To avoid damage in transit, feet are not delivered attached to the radiator. The foot cover must be detached whilst mounting the radiator.

#### Colour

RAL 9010 (same as radiator). Other RAL colours - please contact Hudevad.

9.0

9.1

9.2

9.3

9.4

9.6

9.7

9.8

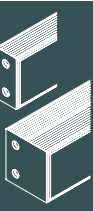

### Dimensions

P200/105 mm: 85 mm deep x 115 mm wide  
 P200/198 mm: 135 mm deep x 65 mm wide  
 Height: 100, 120 or 150 mm

### Position of FDC feet

Fig. 9.3.21  
 P200/105 and P200/198, Profile

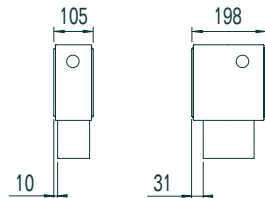

### No. of feet

2

### Position of mounting bolts

Position of mounting bolts and french screws are specified in fig. 9.3.22 to 9.3.25. All P200 types and lengths have same measures for both ends, except P200 with built-in valve Format 1.

Fig. 9.3.22  
 Standard, depth 105

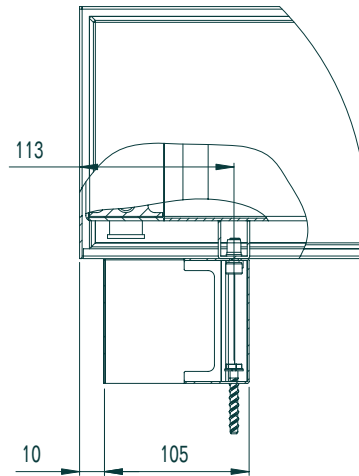

Fig. 9.3.23  
 Built-in valve Format 1, depth 105

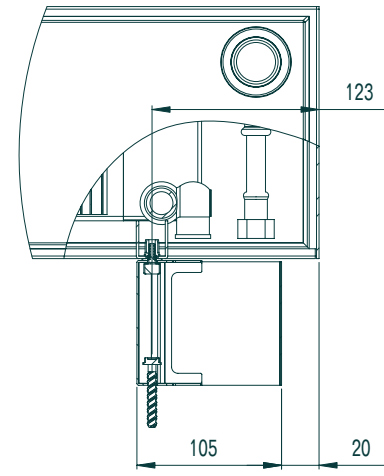

Fig. 9.3.24  
 Standard, depth 198

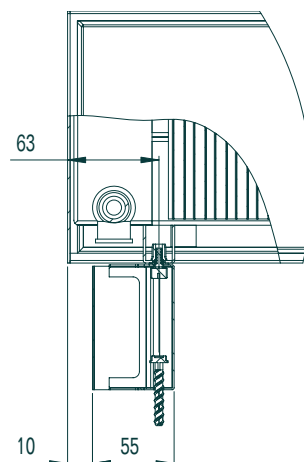
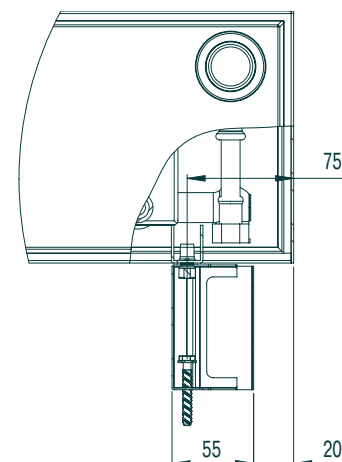

Fig. 9.3.25  
 Built-in valve Format 1, depth 198



9.0



9.1



9.2



9.3



9.4



9.6



9.7



9.8

## Built-in valve

P200

## Built-in valve

VARIANT

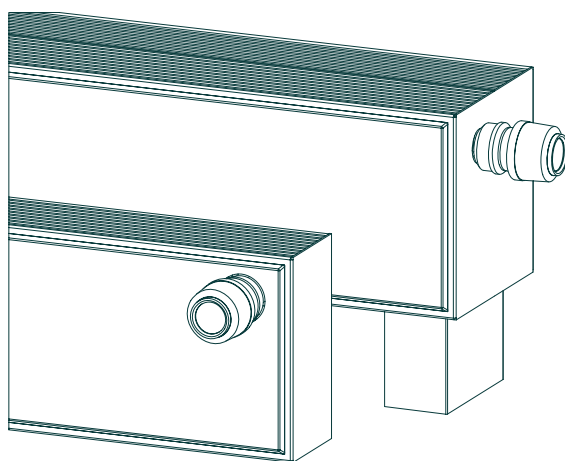

P200 with built-in valve Format 1 (front) and Format 3 (side)

### Application

For use where a thermostatic valve is to be integrated within the radiator, where discreet pipework is required or for ease of installation.

### Construction

The integrated valve and associated pipework is fitted inside the radiator casing. The sensor head projects through a hole in the front plate (Format 1) or the end of the radiator (Format 3). A special integrated valve with pre-setting for limiting the maximum water flow is used. All P200 with built-in valve comes with downwards tappings (E-F, F-E, 2E or 2F).

The valve is supplied factory fitted.

**NOTE:** For other valve options, please contact Hudevad.

**NOTE:** Format 1 is available from 710 mm, as the radiator casing is extended 100 mm to accommodate the built-in valve.

Danfoss sensor head RA 2990 is supplied unless otherwise stated

### Tappings

Formats 1 and 3 have 1/2" tappings

### Position of feet and mounting rails

See pages 9.3.1 - 9.3.8

### Format 1

Sensor head through front plate and 1/2" tappings facing downwards

### Format 3

Sensor head through end and 1/2" tappings facing downwards

9.0

9.1

9.2

9.3

9.4

9.6

9.7

9.8

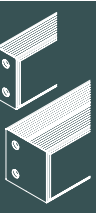

**Built-in valve Format 1,  
wall mounted**

**P200/98**

Fig. 9.4.1  
E-F/F-E tappings

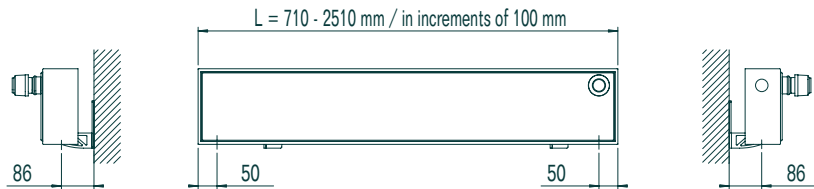
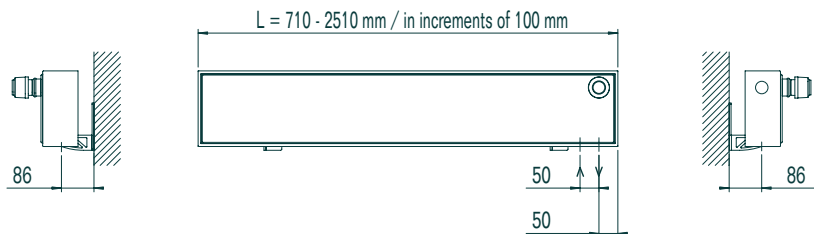

Fig. 9.4.2  
2E/2F tappings



**P200/178**

Fig. 9.4.3  
E-F/F-E tappings

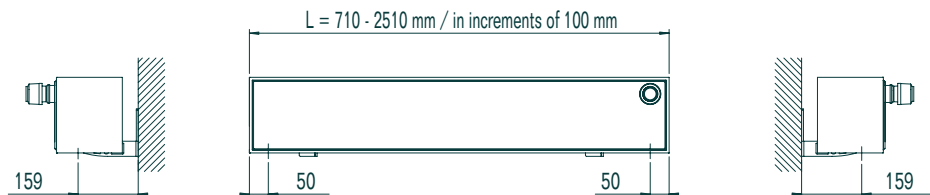
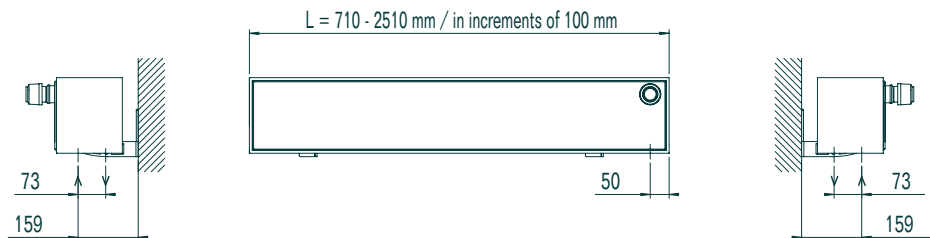

Fig. 9.4.4  
2E/2F tappings



9.0



9.1



9.2



9.3



9.4



9.6



9.7



9.8

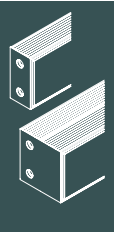

# Built-in valve

P200

## Built-in valve Format 3, wall mounted

P200/98

Fig. 9.4.5  
E-F/F-E tappings

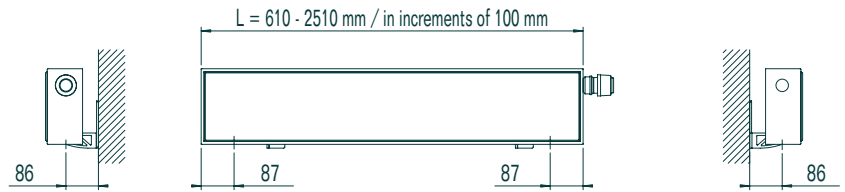
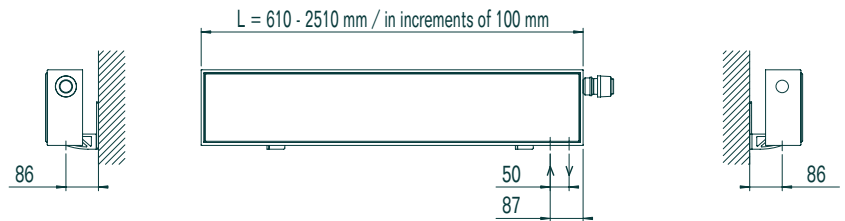

Fig. 9.4.6  
2E/2F tappings



P200/178

Fig. 9.4.7  
E-F/F-E tappings

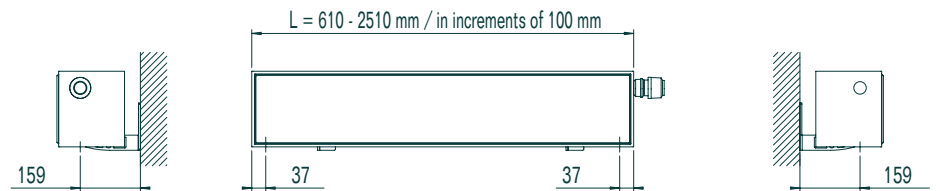
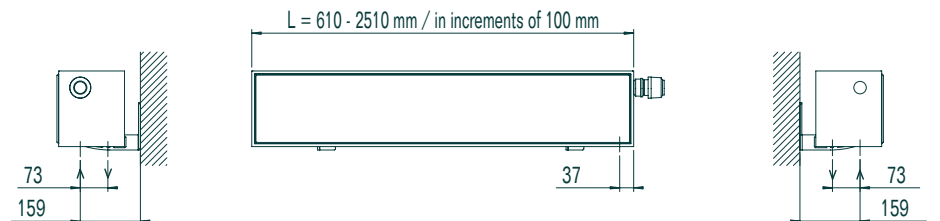

Fig. 9.4.8  
2E/2F tappings



9.0

9.1

9.2

9.3

9.4

9.6

9.7

9.8

9.4.3

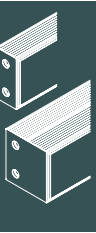

**Built-in valve Format 1,  
floor mounted**

**P200/105**

Fig. 9.4.9  
E-F/F-E tappings

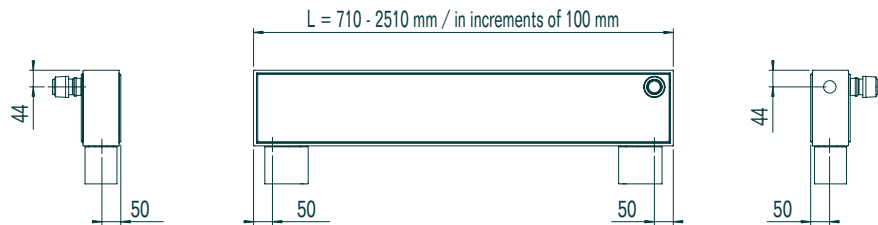
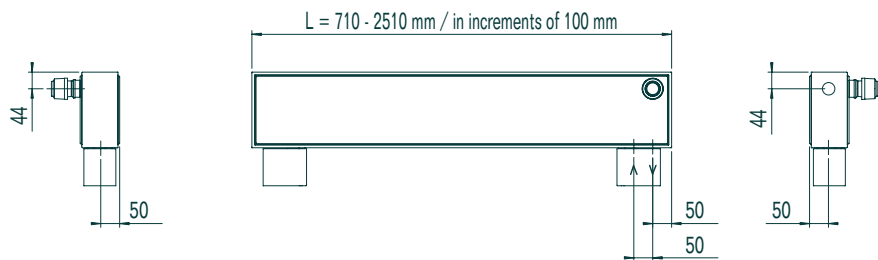

Fig. 9.4.10  
2E/2F tappings



**P200/198**

Fig. 9.4.11  
E-F/F-E tappings

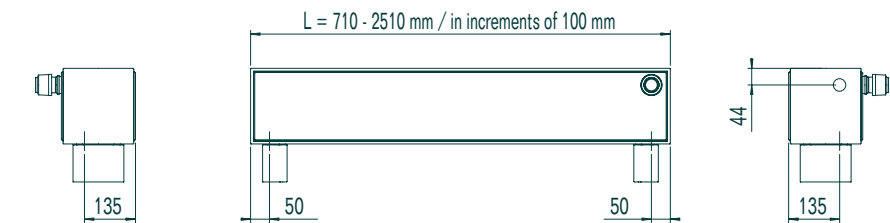
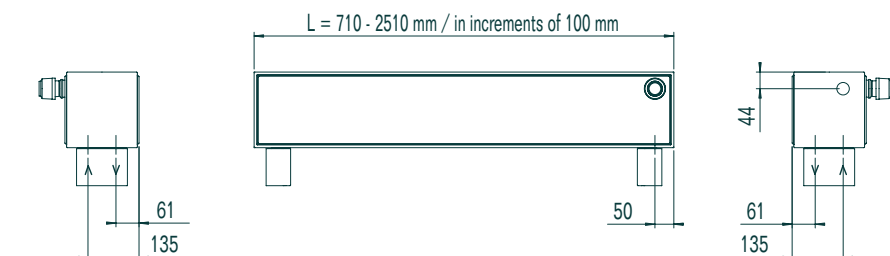

Fig. 9.4.12  
2E/2F tappings



9.0



9.1



9.2



9.3



9.4



9.6



9.7



9.8

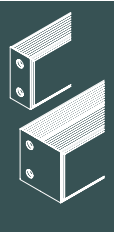

# Built-in valve

P200

## Built-in valve Format 3, floor mounted

P200/105

Fig. 9.4.13  
E-F/F-E tappings

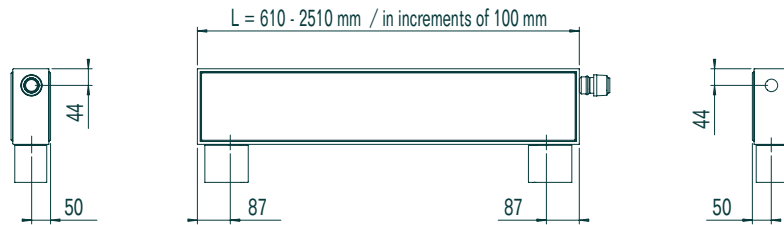
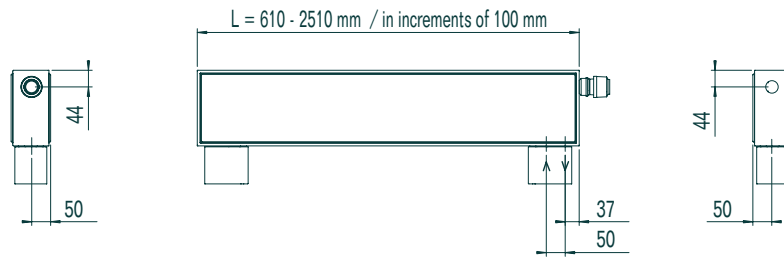

Fig. 9.4.14  
2E/2F tappings



P200/198

Fig. 9.4.15  
E-F/F-E tappings

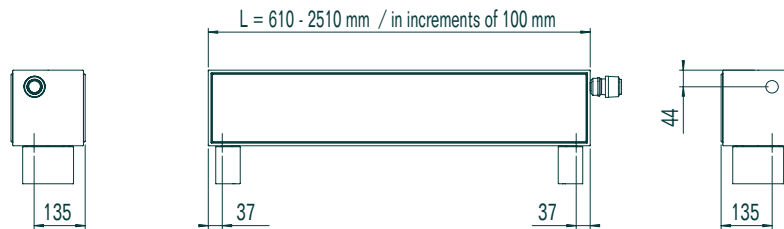
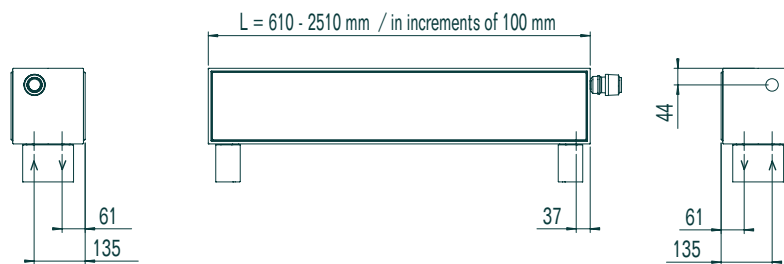

Fig. 9.4.16  
2E/2F tappings



9.0

9.1

9.2

9.3

9.4

9.6

9.7

9.8

9.4.5

## Accessories

P200

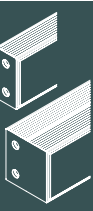

### Air vent with O-ring

1/2" supplied unless otherwise stated.



1 —  
2 —

9.0

### Sensor head

Danfoss sensor head RA 2990 is supplied with built-in valve, unless otherwise stated



9.1



9.2



9.3



9.4



9.6



9.7



9.8

## Standard specification clauses

### P200

#### P200

Hudevad radiator, model P200, with casing made from 2 mm steel plate. Smooth rebated front plate, with closed ends. Integrated aluminium top grille. Internal flat tube heating element with welded on convector fins. P200 is available in single and double depths. P200 floor mounted is supplied with Plan back plate.

Painted with oven dried powder coat or wet coat. Surface treatment in accordance with EN 442.

Test and operating pressure 13 bar/10 bar.

#### FDC feet (page 9.3.7)

“Closed rectangular bolted feet in 2 mm steel, with detachable cover. Mounted to floor with coach screws. all necessary parts and screws are supplied unless otherwise specified.”

#### Built-in valve (page 9.4.1 - 5)

Format 1

“Built-in valve format 1 with sensor head through front plate and bottom tappings.”

Format 3

“Built-in valve format 3 with sensor head through end and bottom tappings.”

#### Order guide

When stating the size and type of radiator, please use the following format: Model / depth - length.

All measurements are to be stated in mm.

Example: For en P200, dybde 98 mm, length 2010 mm, stated: P200/98-2010

**NOTE:** Please state flow and return position.

Example: P200/98-2010, 1/2” E, 1/2” F



9.0



9.1



9.2



9.3



9.4



9.6



9.7



9.8

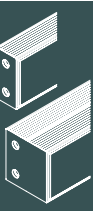

## Maintenance

### Painting of primed radiators

Paint suitable for steel surfaces should be used

### Repair of powder or wet coated radiators

Water based acrylic paint obtained from a decorating wholesaler can be used.

### Recoating of powder or wet coated radiators

After cleaning, powder or wet coated radiators can be recoated with the following:

Powder coat: PE powder

Wet coat: Synthetic, non yellowing coat. Water based or similar acrylic paint.

Hardening: 180°C curing temperature for 10 min.

### Packaging

Packaging can be left on the radiators for protection against damage etc. during fitting and re-decoration, but the flow temperature should not exceed 70°C.

### Venting

Venting of the radiators is required at commissioning, or if the heating system has been drained. It is recommended that radiators are vented, using a cloth to prevent splashing, when the system is cold and the pump is off.

### Cleaning

Light household cleaning materials can be used for painted surfaces. Abrasive materials such as scouring powder should not be used. The rear of the radiator can be cleaned with a soft brush, if necessary, together with a vacuum cleaner.



9.0



9.1



9.2



9.3



9.4



9.6



9.7



9.8

