



**Index**



5A.0

**Product description**



5A.1

**Technical specifications**



5A.2

**Mounting**



5A.3

**Built-in valve**



5A.4

**Accessories**



5A.6

**Specification clauses**



5A.7

**Maintenance**



5A.8





P5-D/P5K-D

## Features

- Elegant, low profile design
- Discreet appearance to compliment any architecture
- Extremely robust and durable without any clip on grilles or side panels
- P5/P5K suitable for mounting at floor or high level
- Creates a continuous appearance when used with Horizon panels
- Electric element option available



5A.0



5A.1



5A.2



5A.3



5A.4



5A.6



5A.7



5A.8

## Product description

### P5-D and P5K-D

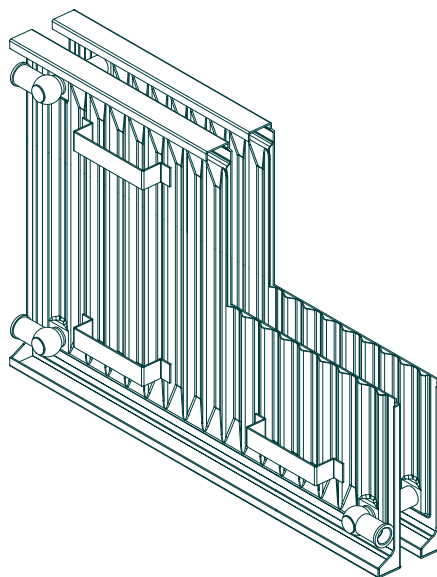

P5-D with cutaway to show waterway, rear view

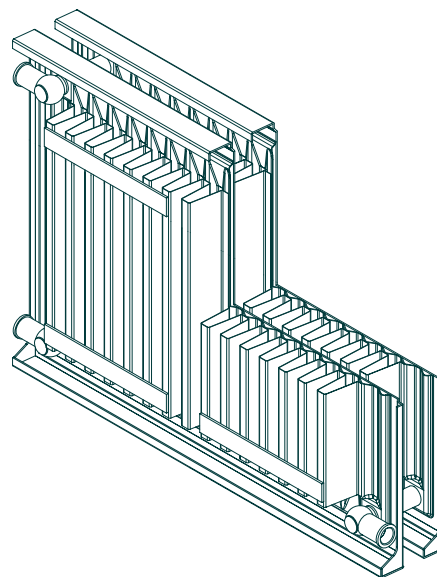

P5K-D with cutaway to show waterway, rear view

#### Description

Each of the 2 panels has a smooth, flat rebated front plate with solid top and bottom and pressed steel rear vertical waterways. P5K-D has convective fins welded on the rear of each panel. Water circulates behind the front plate of each panel, and interconnections allow water to circulate between panels.

#### Material

Front plate: 2.00 mm steel EN 10051  
Rear plate: 1.25 mm steel EN 10130  
P5K-D convective fins: 0.50 mm steel EN 10130

#### Test pressure

10 bar

#### Max. operating pressure

7.7 bar in accordance with EN 442

#### Max. operating temperature

95°C

#### Surface treatment

Pre-treatment:  
• Degreasing and iron-phosphating  
Priming:  
• Primed with water based paint in pale grey colour  
Paint finish:  
• White RAL 9010: Powder PE, gloss approx. 50%  
• Other colours: Powder painted as above or wet painted, gloss approx. 50%  
• Surface treatment in accordance with DIN 55900 and EN 442

#### Outputs

See output tables page 5A.2.1



Fig. 5A.1.1  
Height and length

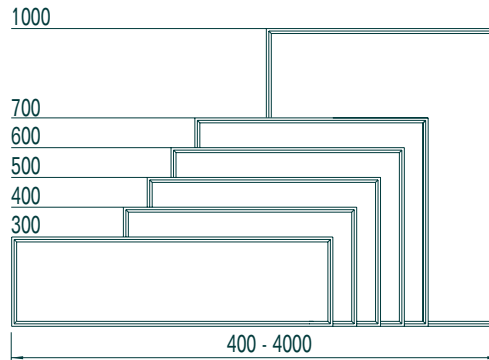
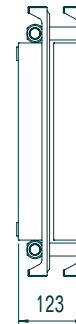

Fig. 5A.1.2  
P5-D, profile



Fig. 5A.1.3  
P5K-D, profile



<b>Length</b>	P5-D/P5K-D: 400-4000 mm, in sectional increments of 33.33 mm
<b>Height</b>	P5-D/P5K-D: 300, 400, 500, 600, 700 and 1000 mm
<b>Depth</b>	P5-D: 105 mm P5K-D: 123 mm
<b>Tappings</b>	1/2" standard, adapter for 3/8" and 3/4" available on request.
<b>Mounting</b>	Wall or floor mounted, see pages 5A.3.1 - 7 Brackets with coach screws, wall plugs and washers are included, see page 5A.3.1 Air vent is supplied, see page 5A.6.10
<b>Colour</b>	Powder coated in white RAL 9010  Option: Painted in other standard RAL and BS colours <b>VARIANT</b>
<b>Packing</b>	Packed securely in environmentally friendly materials.  Mounting is possible without unpacking, for protection. <b>NOTE:</b> Max. flow temperature when using before unpacking of radiator is 70°C
<b>Optional extras (Variant or Individual)</b>	<ul style="list-style-type: none"> <li>• Built-in valve, see pages 5A.4.1 - 3</li> <li>• Horizon infill and end panel system, see pages 5A.6.1 - 8</li> </ul>



5A.0



5A.1



5A.2



5A.3



5A.4



5A.6



5A.7



5A.8

# Technical specifications

## P5-D and P5K-D

### Output

Table 5A.2.1

P5-D	Output			Water content		Weight	
	Height mm	W/metre 75/65-20	W/metre 90/70-20	W/section 90/70-20	litres/metre	litres/section	kg/metre
300	508	699	23.3	1.7	0.06	18.0	0.60
400	667	911	30.4	2.1	0.07	23.2	0.77
500	799	1080	36.0	2.5	0.08	28.4	0.95
600	929	1248	41.6	2.9	0.10	33.6	1.12
700	1056	1409	47.0	3.4	0.11	38.7	1.29
1000	1465	1905	63.5	4.9	0.16	53.3	1.78

Table 5A.2.2

P5K-D	Output			Water content		Weight	
	Height mm	W/metre 75/65-20	W/metre 90/70-20	W/section 90/70-20	litres/metre	litres/section	kg/metre
300	845	1089	36.3	1.7	0.06	22.0	0.73
400	1035	1342	44.7	2.1	0.07	29.2	0.97
500	1187	1551	51.7	2.5	0.08	36.6	1.22
600	1348	1771	59.0	2.9	0.10	44.0	1.47
700	1523	2015	67.2	3.4	0.11	51.2	1.71
1000	2146	2872	95.7	4.9	0.16	73.0	2.43

### Tapping designation



P5-D with side tapping



P5K-D with side tapping

Fig. 5A.2.3  
Tapping designation

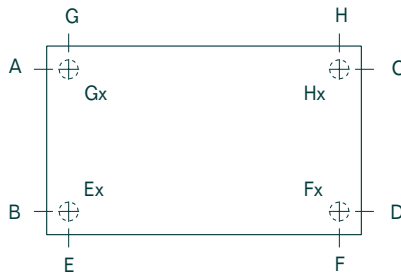
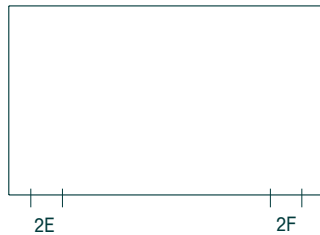

Fig. 5A.2.4  
Tapping designation, 2E and 2F



**Side Tappings**  
**A, B, C, D**

**Sizes**

1/2" standard, adapter for 3/8" and 3/4" available on request

**Position**

Fig. 5A.2.5  
3/8", 1/2" (internal)

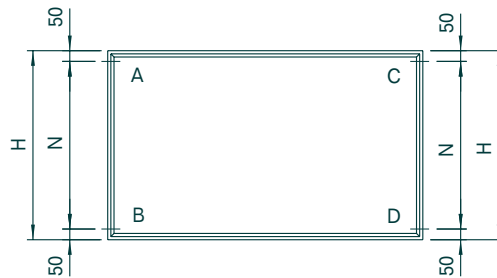

Fig. 5A.2.6  
3/4" (external)

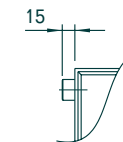
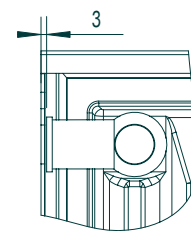

Fig. 5A.2.7



Where radiators exceed 2000 mm, and same-side tappings are required, (A-B or C-D), a rear return tube will be factory-fitted to ensure optimum water flow.

Table 5A.2.8  
Centre distance N for A, B, C, D tappings

Radiator height H, mm	Centre distance N, mm
300	200
400	300
500	400
600	500
700	600
1000	900

Fig. 5A.2.9  
P5-D, profile

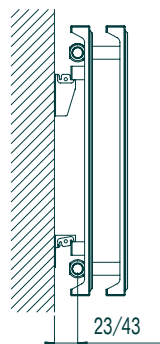
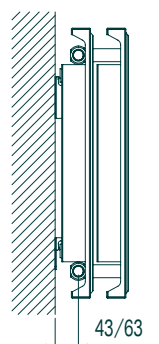

Fig. 5A.2.10  
P5K-D, profile



**Horizon infill and end panels**

Radiators for Horizon infill and end panels (see page 5A.6.1) will be factory fitted with special Horizon extended tappings. If Horizon is required please state this when ordering radiators.

**NOTE:** 3/8" and 3/4" tappings cannot be used with Horizon infill and end panels

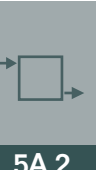

# Technical specifications

*P5-D and P5K-D*

## Top and bottom tapplings E, F, G, H, 2E, 2F

**VARIANT**

### Sizes

1/2" standard, 3/8" variant. 3/4" not available

### Position

Fig. 5A.2.11  
Top and bottom tapplings

Fig. 5A.2.12  
P5-D, profile

Fig. 5A.2.13  
P5K-D, profile

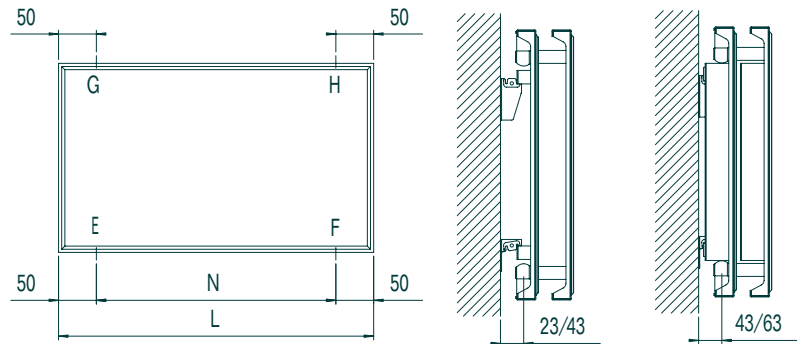

Centre distance N for E-F and G-H tapplings is calculated as:  
Radiator length L – 100 mm

Where radiators exceed 2000 mm, and same-side tapplings are required, (G-E or H-F), a rear return tube will be factory-fitted to ensure optimum water flow.

For G and H top connections the radiator will always be supplied with a rear vertical return tube to ensure optimum water flow - please contact Hudevad.

Fig. 5A.2.14  
2E and 2F tapplings

Fig. 5A.2.15  
P5-D, profile

Fig. 5A.2.16  
P5K-D, profile

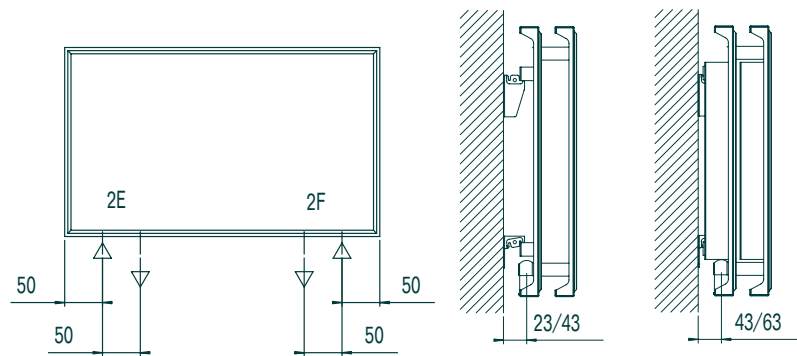

**NOTE:** Flow is always placed in the outer tapping.

### Other option

Other options can be supplied as individual solutions - please contact Hudevad.

**INDIVIDUAL**

**Rear tapplings**  
**Ex, Fx, Gx, Hx**

**VARIANT**

**Sizes**

1/2" standard and 3/8" converters variant

**Position**

Fig. 5A.2.17  
Rear tapplings

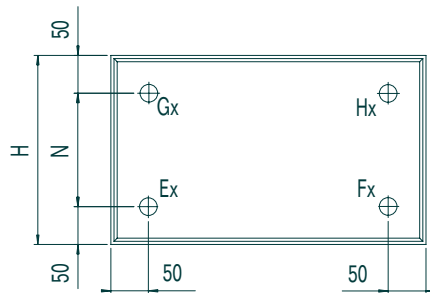

Fig. 5A.2.18  
P5-D, profile

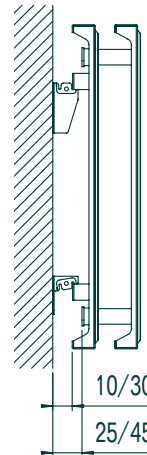

Fig. 5A.2.19  
P5K-D, profile

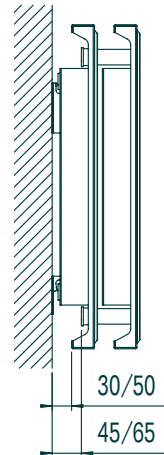

Table 5A.2.20  
Centre distance N for Gx-Ex and Hx-Fx tapplings

Radiator height H, mm	Centre distance N, mm
300	200
400	300
500	400
600	500
700	600
1000	900

Horizontal centre distance for Gx-Hx and Ex-Fx is calculated as:  
Radiator length L – 100 mm

For optimum performance we recommend Gx-Fx or Hx-Ex.

Consideration should be given to the positioning of valves, if rear tapplings are ordered.

**Other option**

Rear tapplings can be tailored to your requirements.

**INDIVIDUAL**

**Water resistance**

Maximum expected pressure loss - calculated from the largest possible radiator.									
Water temperature - flow	$t_f$	°C	75	70	70	65	90	55	
Water temperature - return	$t_r$	°C	65	40	55	35	70	45	
At P5-D: H = 1000 mm and L = 4000 mm									
Pressure loss		kPa	1.5	0.1	0.5	0.1	0.7	0.4	
At P5K-D: H = 1000 mm and L = 4000 mm									
Pressure loss		kPa	3.2	0.2	0.9	0.2	1.6	0.8	
Pressure losses for other heights/lengths can be approximated on a proportional basis									



# Mounting

## P5-D and P5K-D

### Bracket BP10/30

#### Accessory for

P5-D and P5K-D. Supplied unless otherwise stated.

#### Construction

Bracket and spacer in galvanised mild steel with nylon inserts for noise suppression. Coach screws, wall plugs and washers are included.  
Optional wall distance: 10 or 30 mm to rear of radiator.

Fig. 5A.3.1  
Bracket BP10/30

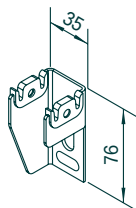

Fig. 5A.3.2  
Bracket BP10/30

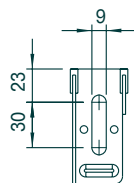
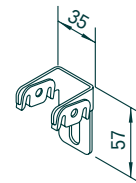

Fig. 5A.3.3  
Spacer for bracket BP10/30



**NOTE:** For tamperproof installation the spacer should be fixed to the wall, see page 5A.3.2

#### Dimensions

P5-D/P5K-D: All radiator heights 300 - 700 & 1000 mm

Fig. 5A.3.4  
P5-D, profile

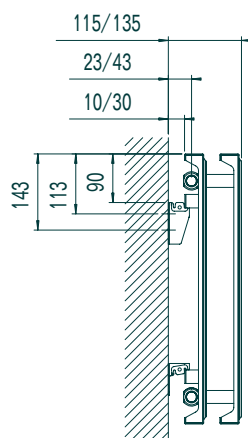

Fig. 5A.3.5  
P5K-D, profile

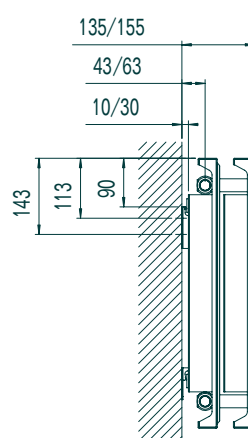
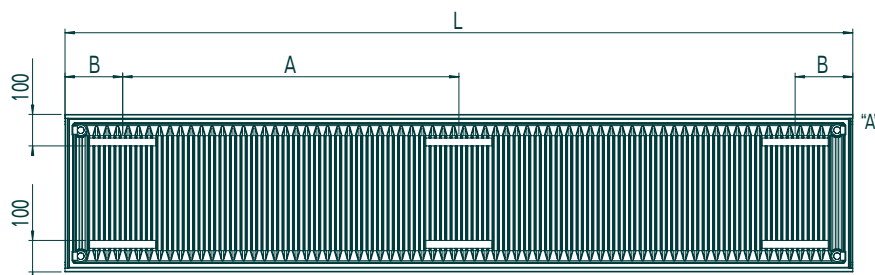

Fig. 5A.3.6

P5-D/P5K-D, all radiator heights 300 - 700 & 1000 mm, position of goal posts, rear view



If no. of brackets/rails is 3 or more and uneven no. of sections, the rail in the middle is displaced 17 mm towards tapping "A".

Table 5A.3.7  
P5-D/P5K-D, position of goal posts and no. of brackets

Radiator length L, mm	No. of sections	No. of brackets/spacers /goal posts	A mm	B mm
400-600	12-18	2/2/2	-	L/2
633-1800	19-54	2/2/4	L-360	180
1833-3600	55-108	3/3/6	(L-360)/2	180
3633-4000	109-120	4/4/8	(L-360)/3	180

### Tamperproof installation

Spacer can be used for tamperproof installation of radiator, see figs. 5A.3.8 - 10

Fig. 5A.3.8  
Loosely mounted spacer

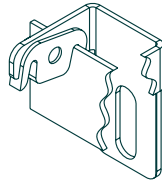

Fig. 5A.3.9  
Fixed spacer, elevated for fixing

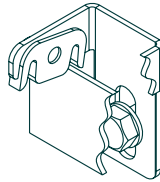
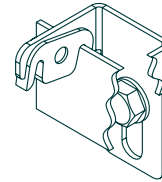

Fig. 5A.3.10  
Spacer in fixed position



5A.0



5A.1



5A.2



5A.3



5A.4



5A.6



5A.7



5A.8

# Mounting

P5-D and P5K-D

## Adjustable brackets BP28-70

VARIANT

### Accessory for

P5-D and P5K-D.

### Application

For use where variable wall distance is required, or where uneven walls prevent the use of fixed brackets

### Construction

Bracket in galvanised mild steel with nylon inserts for noise suppression. Spacer in galvanised mild steel with adjuster screw. Coach screws, wall plugs and washers are included.

Fig. 5A.3.11  
Bracket BP28-70

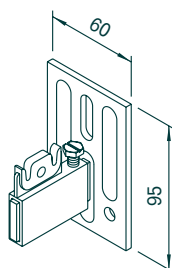

Fig. 5A.3.12  
Bracket BP28-70

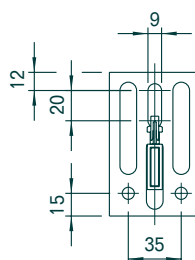
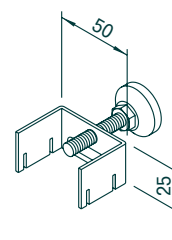

Fig. 5A.3.13  
Spacer for brackets BP28-70



### Dimensions

Fig. 5A.3.14  
P5-D, radiator height  
300 - 700 & 1000 mm, profile

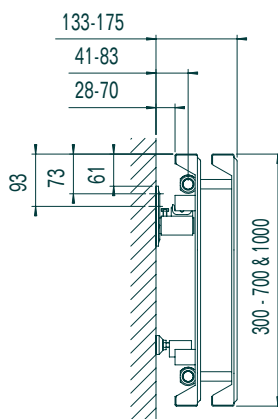
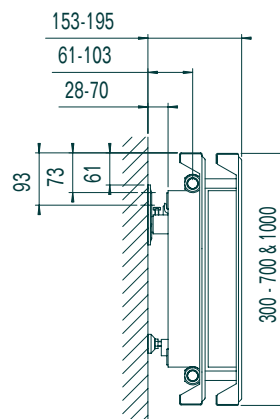

Fig. 5A.3.15  
P5K-D, radiator height  
300 - 700 & 1000 mm, profile



### Position of goal posts/ rails and no. of brackets

See pages 5A.3.1 - 2

**Adjustable feet**  
**PR**

**VARIANT**



P5-D/P5K-D with adjustable feet

Fig. 5A.3.16

PR feet, low

PR feet, high

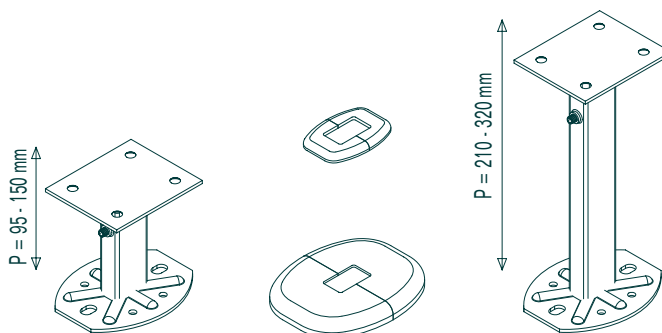

**Accessory for**

P5-D/P5K-D

**Application**

For areas where wall-mounting is not possible, i.e. in front of windows etc.

**Colour**

RAL 9010 (same as radiator)

Fig. 5A.3.16/A

P5-D with feet PR, profile

Fig. 5A.3.16/B

P5K-D with feet PR, profile

Fig. 5A.3.16/C

Foot plate for feet PR, plan view

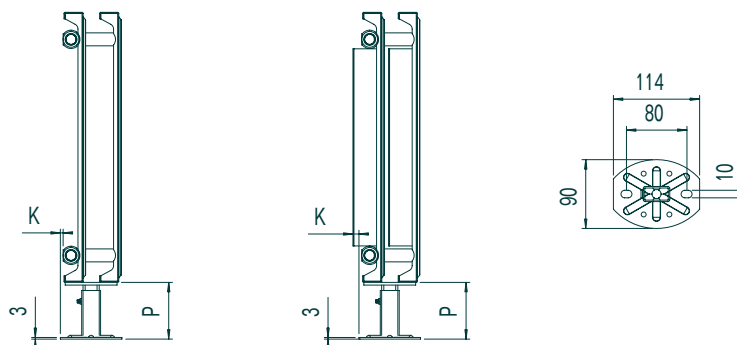

**NOTE:** If rose fitted add 5 mm each side

Smallest wall distance is K + thickness of skirting, see table 5A.3.16/D

Table 5A.3.16/D

Distance K for foot plate

Depth, mm	K, mm
105	5
123	-11



5A.0



5A.1



5A.2



5A.3



5A.4



5A.6



5A.7



5A.8

# Mounting

## P5-D and P5K-D

### Position and no. of feet

Fig. 5A.3.17  
Radiator with 2 feet

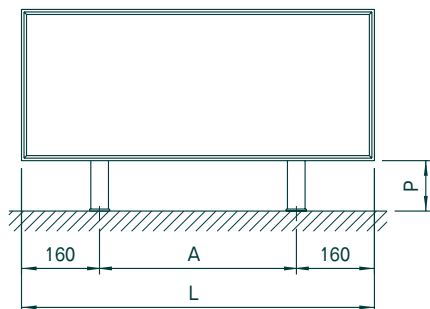

Fig. 5A.3.18  
Radiator with 3 feet

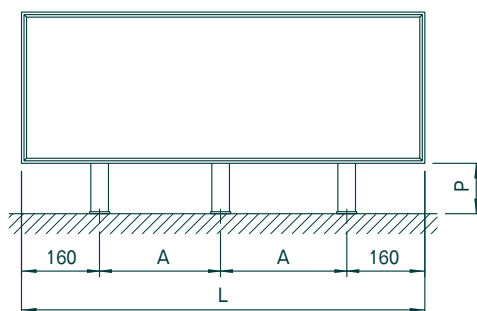

Fig. 5A.3.19  
Radiator with 4 feet

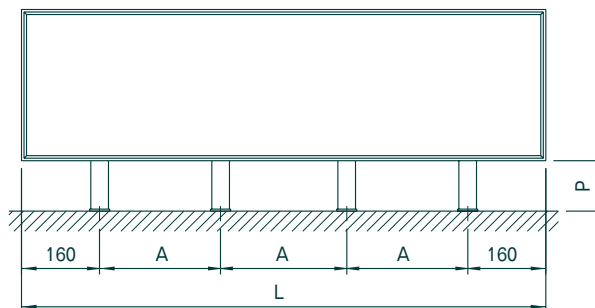

Table 5A.3.20  
Position and no. of feet

Radiator length L, mm	No. of sections	No. of feet	A mm
400-600	12-18	2	-
633-1800	19-54	2	L-320
1833-3600	55-108	3	(L-320)/2
3633-4000	109-120	4	(L-320)/3

**NOTE:** Hudevad do not recommend the use of feet for heights 700 and 1000 mm, without additional top restraints being used.

**Console feet**  
**FH3-FH7 & FH10**

**VARIANT**

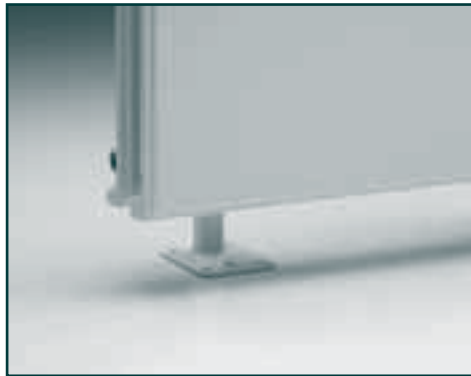

P5-D with console feet FH

**Accessory for**

P5-D/P5K-D

**Application**

For use where wall mounting is not possible. The foot plate can be fixed through a raised floor or embedded in concrete. Console feet allows the radiator to be adjusted in height.

**Colour**

Upright and foot plate: Powder coated in white RAL 9010  
Adjustable collars: Galvanised

**Dimensions**

Fig. 5A.3.21  
FH3-7 & FH10 for P5-D,  
profile

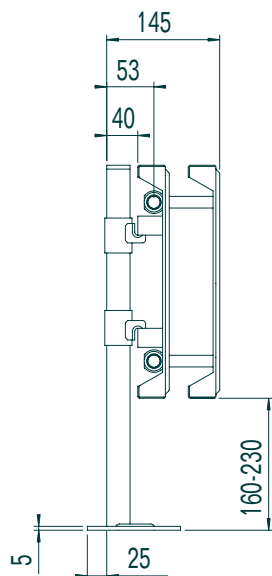

Fig. 5A.3.22  
FH3-7 & FH10 for P5K-D,  
profile

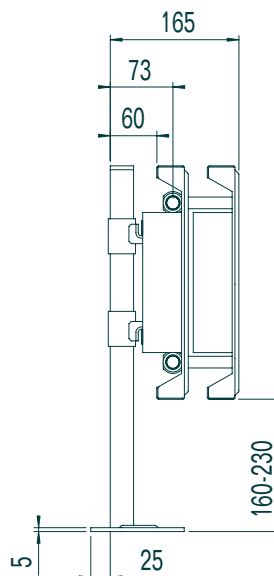
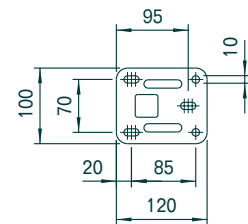

Fig. 5A.3.23  
FH3-7 & FH10 foot plate,  
plan view



**NOTE:** If greater or lesser height from floor is required, taller or shorter feet FH can be selected, e.g. FH4 for radiator height 500 mm

**Other feet**

Individual solutions



## Mounting

### P5-D and P5K-D

#### Position of rails/goal posts

See pages 5A.3.1 - 2

#### No. of feet and type

Table 5A.3.24

No. of feet FH

Radiator length L, mm	No. of sections	No. of feet
400-1800	12-54	2
1833-3600	55-108	3
3633-4000	109-120	4

Table 5A.3.25

Type of feet FH

Radiator height H, mm	Height of feet mm	Type of feet
300	460	FH3
400	560	FH4
500	660	FH5
600	760	FH6
* 700	860	FH7
* 1000	1160	FH10

**\* NOTE:** Hudevad do not recommend the use of feet for heights 700 and 1000 mm, without additional top restraints being used.

**Built-in valve**

**VARIANT**

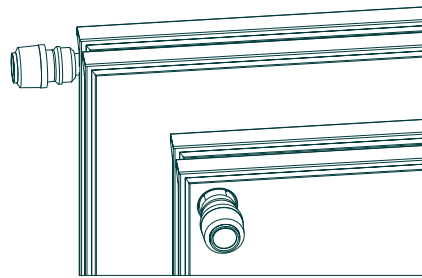

P5-D/P5K-D with built-in valve  
Format 1 (front) and Format 3 (side)

**Application**

For use where a thermostatic valve is to be integrated within the radiator, where discreet pipework is required or for the ease of installation.

**Construction**

The valve and associated pipework are fitted behind the radiator. On P5K-D the number of convector fins is reduced to accommodate the built-in valve, resulting in a total output loss of approx 30-50 watts depending on height. The sensor head projects through a hole in the front plate (Format 1) or the side of the radiator (Format 3). A special integrated valve with pre-setting for limiting the maximum water flow is used.

There are different valve head options to suit the following valve bodies:

- 1: Danfoss type RA-N Integrated valve body to suit Danfoss heads having click-on coupling.
- 2: Danfoss type RA-N Integrated valve body, with M30 x 1.5 mm connection thread adapter, to suit Oventrop, Heimeier, MNG, Drayton and Honeywell sensors.

**NOTE:** Built in valves are only available in 1/2". Please note the built in thermostatic valve does not isolate the radiator, additional isolation and lockshield valves are still required.

**Tappings**

Formats 1 and 3 all have 1/2" tappings. For Format 1 and 3 combinations 2E, 2F or E-F can be ordered. The airvent will be opposite the built-in valve.

**Position of goal posts/rails**

See pages 5A.3.1 - 2

**Format 1**

Sensor head through front plate and 1/2" downward facing tappings

Fig. 5A.4.1  
P5-D and P5K-D, built-in valve  
Format 1

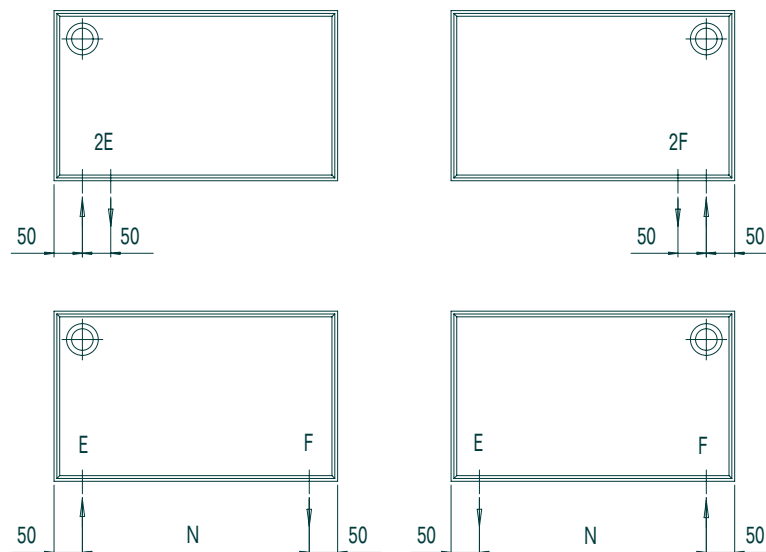

Centre distance N is calculated as: Radiator length – 100 mm



## Built-in valve

### *P5-D and P5K-D*

Fig. 5A.4.2

P5-D, built-in valve Format 1, profile

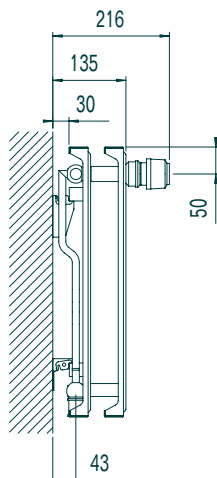
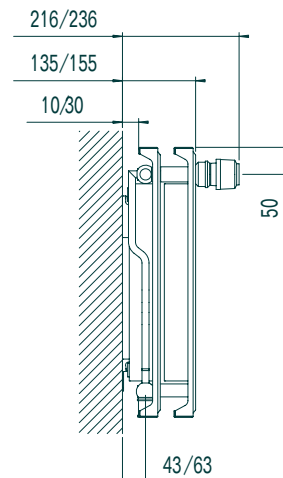

Fig. 5A.4.3

P5K-D, built-in valve Format 1, profile



**NOTE:** Measurements are for Danfoss sensor head RA 2990.

1  
2

5A.0



5A.1



5A.2



5A.3



5A.4



5A.6



5A.7



5A.8

**Format 3**

Sensor head, side-facing and 1/2" downward facing tappings

**VARIANT**

Fig. 5A.4.4  
P5-D and P5K-D, built-in valve Format 3

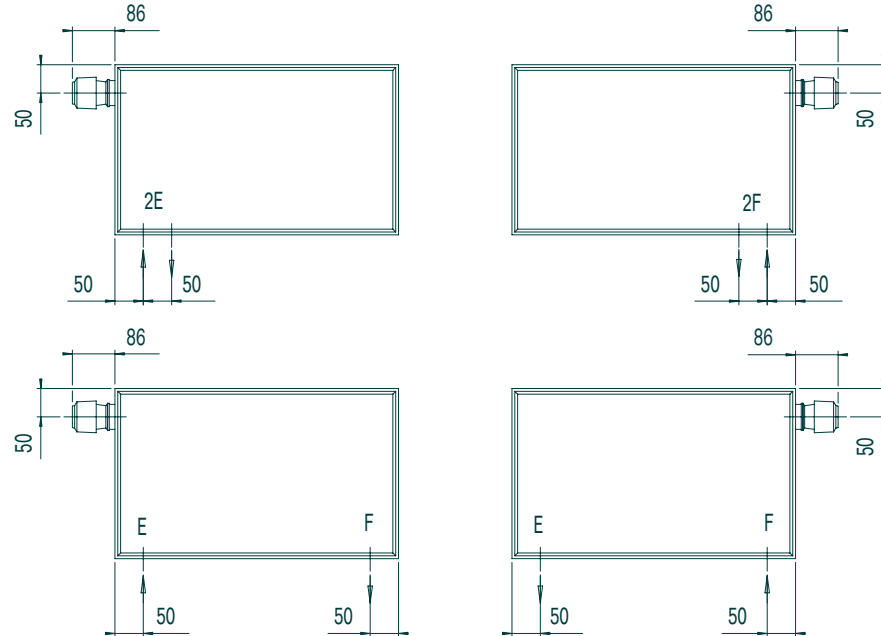

**NOTE:** Measurement is for Danfoss sensor head RA 2990.

Fig. 5A.4.5  
P5-D, built-in valve Format 3, profile

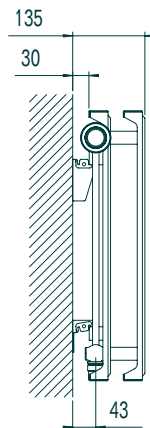
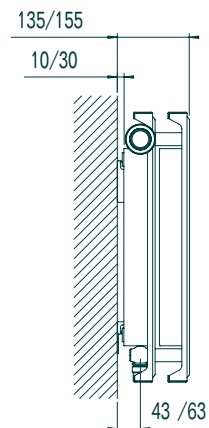

Fig. 5A.4.6  
P5K-D, built-in valve Format 3, profile



**NOTE:** Min. wall distance for P5-D is 30 mm

**Ordering**

When ordering please state the built-in valve format, type of sensor head connections, position of valve - left or right hand - and the tapping requirements.  
Example: P5-D 500/105 - 2000, Format 1, Danfoss, left, 1/2" E & F

**For other sensor heads**

Please contact Hudevad.

## Accessories

### P5-D and P5K-D

#### Horizon infill and end panels

VARIANT



P5-D/P5K-D with Horizon infill panel

#### Accessory for

P5-D and P5K-D

**NOTE:** It is only possible to incorporate Horizon panels where P5-D/P5K-D radiators have been provided with 1/2" tappings.

#### Application

For use where several radiators are mounted to create a continuous appearance which can be used to conceal electrical and pipework installations. Horizon can be supplied as infill panels for mounting between radiators or as end panels with either open or boxed ends.

#### Construction

Smooth rebated front plate and solid top. Folded edge to conceal gap between radiator and infill or end panel. Mounted on extended Horizon tappings using spring clips at the top and bottom, and wall brackets and spacers where necessary.

#### Material

2.00 mm steel plate, EN 10051

Fig. 5A.6.1

Horizon system, front view

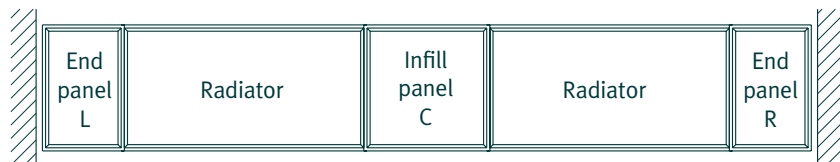
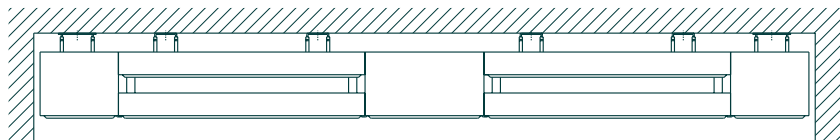

Fig. 5A.6.2

Horizon system, plan view





**Length**

Horizon infill panels: 120-2500 mm in increments of 1 mm  
 Horizon end panels: 150-2500 mm in increments of 1 mm  
**NOTE:** If radiators are inter-connected behind infill panels then length of the infill panel will have to be long enough to accommodate associated pipework; see fig 5A.6.3.  
 Max. radiator length is 4000 mm when using special Horizon tappings, see fig. 5A.6.3

Fig. 5A.6.3  
 Horizon tappings on P5-D and P5K-D

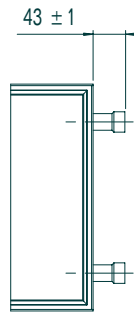

**Height**

Same as radiator

**Depth**

105 mm

**Optional extras**

Please contact Hudevad

**Horizon infill panels**

Infill panels are factory fitted with spring clips at each corner for fixing on 1/2 Horizon tappings or dummy tappings of the radiator, see fig. 5A.6.4

Fig. 5A.6.4  
 Fitting Horizon infill or end panel with spring clips and min. distance above radiator

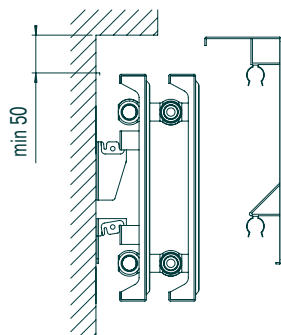

Infill panels longer than 1000 mm are, in addition to the 4 spring clips, fitted with goal posts for fixing to walls and for possible tamperproof fixing, see fig. 5A.6.5



5A.0



5A.1



5A.2



5A.3



5A.4



5A.6



5A.7



5A.8

## Accessories

### P5-D and P5K-D

Fig. 5A.6.5

Horizon spacer with tamperproof fixing, profile

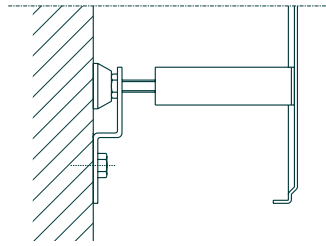

**NOTE:** If a tamperproof fixing is required on infill panels shorter than 1000 mm, please state this when ordering.

Fig. 5A.6.6

Horizon infill panels, position of goal posts at length 1001-1500 mm, rear view

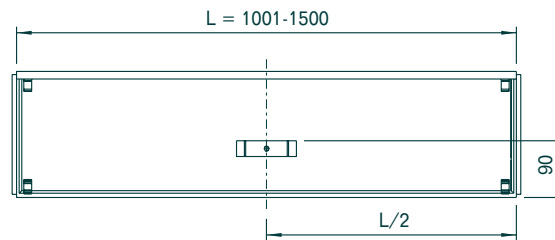
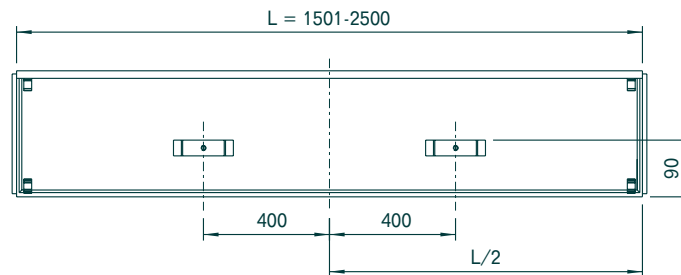

Fig. 5A.6.7

Horizon infill panels, position of goal posts at length 1501-2500 mm, rear view





**Horizon end panels**

Horizon end panels are fitted with spring clips for fixing on the special Horizon tappings. At the opposite end, goal posts are provided for mounting on brackets and spacers. All end panels are supplied with tamperproof fixings, see fig. 5A.6.8.

Fig. 5A.6.8  
Fitting Horizon end panel with brackets and spacers, with tamperproof fixing, at opposite side to radiator and min. distance above radiator

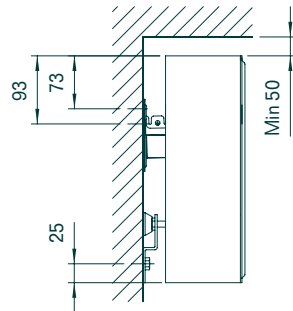

**Boxed ends**

Horizon end panels can be ordered with boxed ends



5A.0



5A.1



5A.2



5A.3



5A.4



5A.6



5A.7



5A.8

# Accessories

## P5-D and P5K-D

Fig. 5A.6.9

Horizon end panels, position of goal posts at length 150-1000 mm, rear view

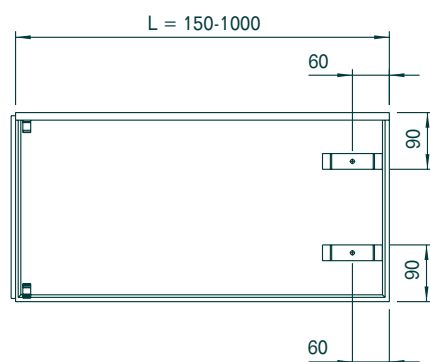

Fig. 5A.6.10

Horizon end panels, position of goal posts at length 1001-1500 mm, rear view

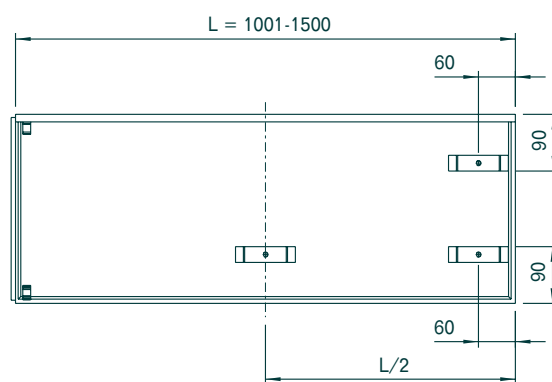
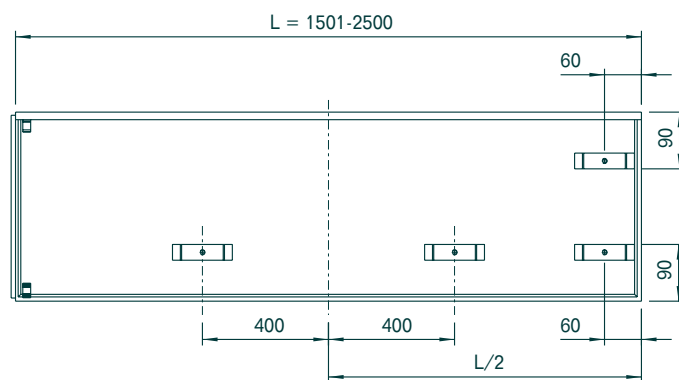

Fig. 5A.6.11

Horizon end panels, position of goal posts at length 1501-2500 mm, rear view



**Mounting**

Radiators for Horizon are factory fitted with extended Horizon tappings. When ordering please state that the radiators are to be prepared for Horizon infill or end panels. Infill and end panels are supplied with wall bracket BH10-48.

Fig. 5A.6.12  
Bracket BH10-48

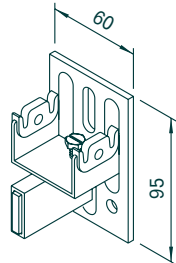

Fig. 5A.6.13  
Bracket BH10-48

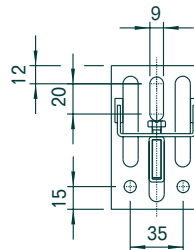

Fig. 5A.6.14  
Horizon spacer



Fig. 5A.6.15  
Horizon spacer with tamperproof fixing, profile

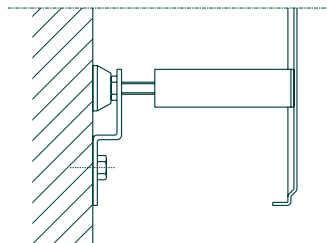
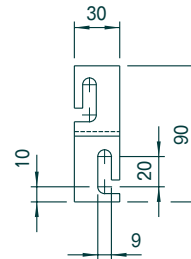

Fig. 5A.6.16  
Horizon spacer with tamperproof fixing, front view



**High level**

Please state at time of order whether Horizon panels will be installed at high level. Tamperproof fixings must be used.

**Hole for valve**

Horizon infill and end panels can be supplied with cut out for thermostatic valve head, see fig. 5A.6.17.

**INDIVIDUAL**

Fig. 5A.6.17  
Horizon infill and end panels,  
position of hole for valve

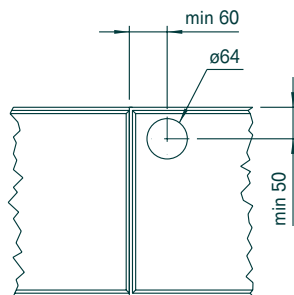

**NOTE:** Position of hole cannot be determined until after mounting of valve. When mounting valve min. distances must be taken into account, see fig. 5A.6.17. The valve cannot be mounted directly in the standard tapping of the radiator. If required the tapping must be ordered repositioned in accordance with the above dimensions, please consult Hudevad.



## Accessories

### P5-D and P5K-D

#### Hole for electric socket

Can be supplied within min. dimensions. See fig 5A.6.18 for minimum clearance.

Fig. 5A.6.18

Horizon infill or end panels can be supplied with cut outs for electric, data or communication sockets. Please contact Hudevad for further details.

INDIVIDUAL

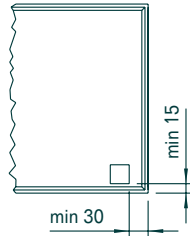

#### Ordering

Please state:

- Hudevad recommend that radiators are fixed & piped prior to taking measurements for the Horizon panels.
- Dimensions Mt and Mb as fixed measurement between the radiators or the required length of end panels. A 5 mm shadow gap between panel and wall is recommended.
- Specification for every infill and end panel position in relation to radiator: L (to the left of radiator), R (to the right of radiator) or C (between 2 radiators).

Fig. 5A.6.19

Measurements

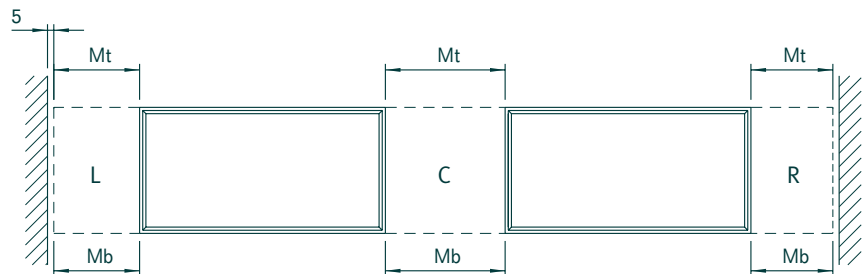

**Horizon angled infill and end panels**

Min. internal angle  $V$ :  $45^\circ$   
 Max. external angle  $V$ :  $270^\circ$   
 Max. 1 angles per infill or end panel

Fig. 5A.6.20  
 Internal angle

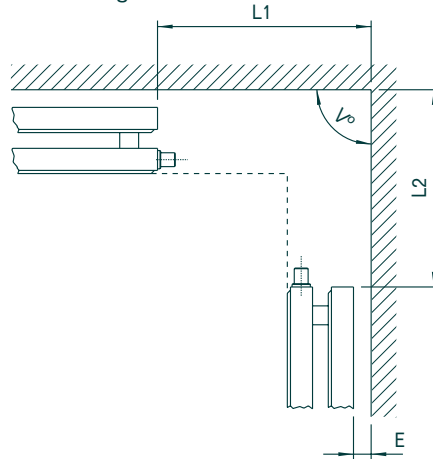

Fig. 5A.6.21  
 Internal angle

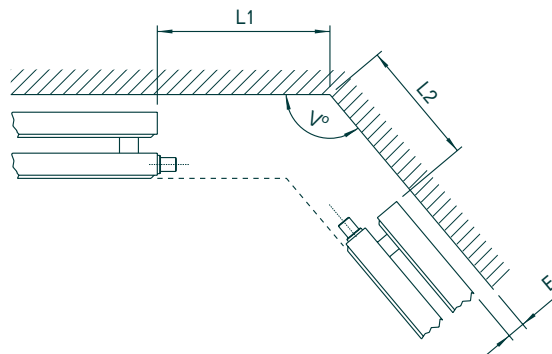
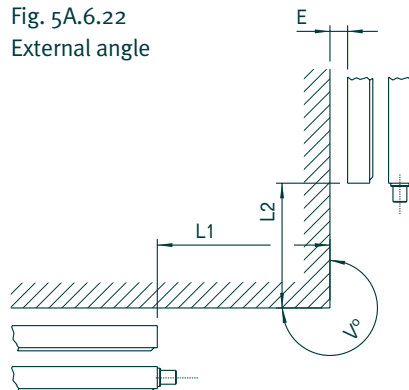

Fig. 5A.6.22  
 External angle



**Ordering**

For every Horizon infill or end panel please state wall distance E, wall length L1 and L2 at top and bottom and angle V with  $0.1^\circ$  increments. Goal posts are provided for brackets and spacers near the angle (corner) for added stability.



5A.0



5A.1



5A.2



5A.3



5A.4



5A.6



5A.7



5A.8

## Accessories

### *P5-D and P5K-D*

#### Air vent with O-ring

1/2" supplied unless otherwise specified.



#### Air vent with O-ring and revolving spout

1/2"



#### Plug with O-ring

1/2"



#### Square key for air vents



#### Sensor head

Danfoss RA 2990  
Supplied unless otherwise specified.



#### Electric element

Supplied separately by Hudevad in combination  
with radiator prepared for electrical heating element

1  
2

5A.0



5A.1



5A.2



5A.3



5A.4



5A.6



5A.7



5A.8

5A.6.9



<b>P5-D</b>	<p>“Hudevad P5-D model 2 panel radiator with smooth, flat 2.00 mm thick rebated front plate, solid top and bottom and 1.25 mm rear plate and pressed steel vertical waterways. Water circulates directly behind the front plate of each panel, and interconnections allow water to circulate between panels. No detachable clip-ons or covers. Painted with oven dried powder coat or wet coat. Surface treatment in accordance with DIN 55900 and EN 442. Test and operating pressure 10, 7.7 bar respectively.”</p>
<b>P5K-D</b>	<p>“Hudevad P5K-D model 2 panel radiator with smooth, flat 2.00 mm thick rebated front plate, solid top and bottom and 1.25 mm rear plate and pressed steel vertical waterways. P5K-D has 0.50 mm convector fins welded-on the rear waterways of each panel. Water circulates directly behind the front plate of each panel, and interconnections allow water to circulate between panels. No detachable clip-ons or covers. Painted with oven dried powder coat or wet coat. Surface treatment in accordance with DIN 55900 and EN 442. Test and operating pressure 10, 7.7 bar respectively.”</p>
<b>Adjustable bracket BP (page 5A.3.3)</b>	<p>“Wall mounted on adjustable brackets with nylon inserts for noise suppression and adjustable spacers.”</p>
<b>Adjustable feet PR (page 5A.3.5)</b>	<p>“Adjustable feet in 2 mm square steel tube rectangular, welded directly to the 3 mm steel foot plate. Painted same colour as radiator. Mounted with coach screws.”</p>
<b>Console feet FH (page 5A.3.6)</b>	<p>“Console feet FH, from 30 x 30 mm steel tube with height adjustable collars and 5 mm foot plate, in radiator colour.”</p>
<b>Built-in valve (page 5A.4.1)</b>	<p>Format 1: “Built-in valve Format 1 with sensor head through front plate and bottom tappings.”</p> <p>Format 3: “Built-in valve Format 3 with sideways facing sensor head and bottom tappings.”</p>



5A.0



5A.1



5A.2



5A.3



5A.4



5A.6



5A.7



5A.8

## Specification clauses

### *P5-D and P5K-D*

#### Horizon infill and end panel (page 5A.6.1)

“Horizon infill and end panels for installation between Hudevad P5-D and P5K-D range. Constructed in 2 mm steel with a smooth rebated front plate, solid top and bottom and folded edge to conceal gap between radiator and infill or end panel. Horizon panels to be mounted on extended Horizon tappings using spring clips at top and bottom, and wall brackets and spacers where necessary, tamperproof option available and recommended for high level installations.”

#### Order guide

When stating the size and type of radiator, please use the following format: Model height / depth - length. All measurements are to be stated in mm.

P5K-D 500/123 - 2000 1/2" A, 1/2" B, 1/2" C, 1/2" D  
Please state flow and return position



5A.0



5A.1



5A.2



5A.3



5A.4



5A.6



5A.7



5A.8



## **Maintenance**

### **Painting of primed radiators**

Paint suitable for steel surfaces should be used

### **Repair of powder or wet coated radiators**

Water based acrylic paint obtained from a decorating wholesaler can be used

### **Recoating of powder or wet coated radiators**

After cleaning, powder or wet coated radiators can be recoated with the following:

Powder coat: PE powder

Wet coat: Synthetic, non yellowing coat. Water based or similar acrylic paint

Hardening: 180°C curing temperature for 10 min.

### **Packaging**

Packaging can be left on the radiators for protection against damage etc. during fitting and re-decoration, but the flow temperature should not exceed 70°C.

### **Venting**

Venting of the radiators is required at commissioning, or if the heating system has been drained. It is recommended that radiators are vented, using a cloth to prevent splashing, when the system is cold and the pump is off.

### **Cleaning**

Light household cleaning materials can be used for painted surfaces. Abrasive materials such as scouring powder should not be used. The rear of the radiator can be cleaned with a soft brush, if necessary, together with a vacuum cleaner.



5A.0



5A.1



5A.2



5A.3



5A.4



5A.6



5A.7



5A.8

