



Index



4.0

Product description



4.1

Technical specifications



4.2

Mounting



4.3

Built-in valve



4.4

Angled and curved radiators



4.5

Accessories



4.6

Standard specification clauses



4.7

Maintenance



4.8

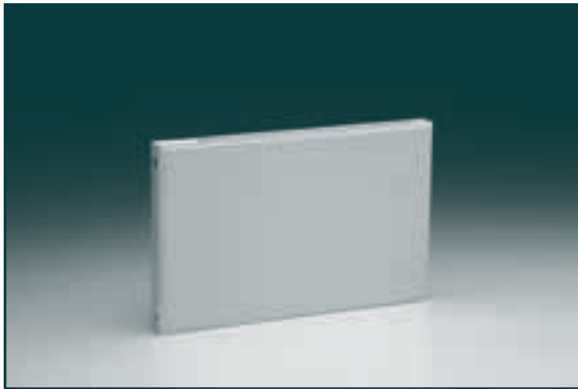

Plan® single



Plan® double



4.0



4.1



4.2



4.3



4.4



4.5



4.6



4.7



4.8

Features

- Simple, timeless design that matches any architecture
- Can be used as an active building component, pronounced or discreet
- Extremely robust and durable without any clip-on grilles or side panels
- Very adaptable with several tapping positions
- Easy to clean due to flat front and open rear fins that are easy to access
- Wide choice of sizes to meet any need
- Plan® single can be angled or curved to match building shapes
- Creates a continuous heating band with Horizon panels
- Range of stock sizes

Product description

Plan®

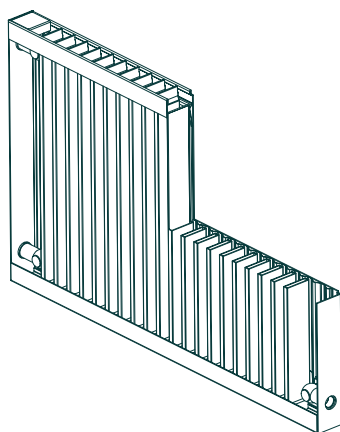

Plan® single with cutaway, rear view

Description

Radiator made from steel plate. Smooth, rebated front plate with closed ends, with pressed steel vertical waterways. Water filled ribs welded on rear plate. Water circulates directly behind the front plate and in the ribs. Plan® double (depths 126 and 166 mm) consists of 2 Plan® single, with interconnections which allow water to circulate between panels.

Material

Front plate: 2.00 mm steel to EN 10051
Rear plate: 1.25 mm steel to EN 10130
Plan® waterfilled ribs: 1.50 mm steel to DIN 2395

Test pressure

10 bar

Max. operating pressure

7.7 bar in accordance with EN 442

Max. operating temperature

95°C

Surface treatment

Pretreatment:
• Degreasing and iron-phosphating
Priming:
• Primed with water based paint in pale grey
Paint finish:
• White RAL 9010: Powder PE, gloss approx. 50%.
• Other colours: Powder painted as above or wet painted gloss approx. 50%
• Surface treatment in accordance with DIN 55900 and EN 442

Output

See output tables, page 4.2.1

4.0

4.1

4.2

4.3

4.4

4.5

4.6

4.7

4.8

Fig. 4.1.1
Height and length

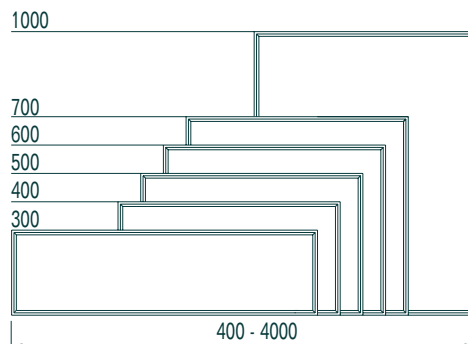
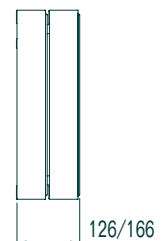

Fig. 4.1.2
Plan® single,
profile



Fig. 4.1.3
Plan® double,
profile



Length

Plan® single and double:
400-4000 mm (12-120 sections) in standard increments of 100 mm
Radiator length, in mm, is calculated as: No. of sections x 33.33 mm
(increments can be at 33.33 mm)

NOTE: Max. radiator length depends on weight: max. 250 kg.

Height

300, 400, 500, 600, 700 and 1000 mm

Depth

Plan® single: 40, 60 and 80 mm
Plan® double: 126 and 166 mm

Tappings

1/2" standard, adapter for 3/8" and 3/4"

Mounting

Wall or floor mounted, see pages 4.3.1 - 9
Brackets are included, see page 4.3.1
Air vent is supplied, see page 4.6.2

Colour

Powder coated in white RAL 9010

Option: Painted in other standard RAL or BS colours

VARIANT

Packing

Packed securely in environmentally friendly materials.

Mounting is possible without unpacking, for protection.

NOTE: Max. flow temperature when commissioning before unpacking of radiator is 70°C

Optional extras (Variant or Individual)

- Built-in valve, see pages 4.4.1 - 7
- Model UR-flex, see pages 4.4.8 - 10
- Angled or curved, see pages 4.5.1 - 4
- Horizon infill and end panel system - please contact Hudevad

Output

Table 4.2.1

Plan® single Depth 40 mm	Output			Water content		Weight	
	Height mm	W/metre 75/65-20	W/metre 90/70-20	W/section 75/65-20	litres/ metre	litres/ section	kg/ metre
300	455	578	15.2	1.9	0.06	16.6	0.55
400	568	724	18.9	2.6	0.09	21.8	0.73
500	674	861	22.5	3.4	0.11	26.7	0.89
600	782	1000	26.1	4.1	0.14	31.5	1.05
700	892	1142	29.7	4.7	0.16	36.2	1.21
1000	1235	1589	41.2	7.0	0.23	51.5	1.72

Table 4.2.2

Plan® single Depth 60 mm	Output			Water content		Weight	
	Height mm	W/metre 75/65-20	W/metre 90/70-20	W/section 75/65-20	litres/ metre	litres/ section	kg/ metre
300	567	724	18.9	2.7	0.09	20.5	0.68
400	706	903	23.5	3.7	0.12	27.0	0.90
500	840	1075	28.0	4.9	0.16	33.2	1.11
600	970	1242	32.3	5.9	0.20	39.3	1.31
700	1097	1406	36.6	7.0	0.23	45.3	1.51
1000	1477	1896	49.2	10.4	0.35	64.5	2.15

Table 4.2.3

Plan® single Depth 80 mm	Output			Water content		Weight	
	Height mm	W/metre 75/65-20	W/metre 90/70-20	W/section 75/65-20	litres/ metre	litres/ section	kg/ metre
300	665	849	22.2	3.5	0.12	24.4	0.81
400	837	1072	27.9	4.9	0.16	32.2	1.07
500	998	1279	33.3	6.4	0.21	39.7	1.32
600	1153	1477	38.4	7.8	0.26	47.1	1.57
700	1302	1669	43.4	9.3	0.31	54.4	1.81
1000	1731	2219	57.7	13.7	0.46	77.5	2.58

Table 4.2.4

Plan® double Depth 126 mm	Output			Water content		Weight	
	Height mm	W/metre 75/65-20	W/metre 90/70-20	W/section 75/65-20	litres/ metre	litres/ section	kg/ metre
300	969	1236	32.3	5.4	0.18	41.0	1.37
400	1209	1553	40.3	7.5	0.28	54.0	1.80
500	1430	1837	47.7	9.8	0.33	66.5	2.22
600	1643	2111	54.8	11.9	0.40	78.6	2.62
700	1850	2378	61.7	14.0	0.47	90.6	3.02
1000	2443	3142	81.4	20.7	0.69	129.0	4.30

Table 4.2.5

Plan® double Depth 166 mm	Output			Water content		Weight	
	Height mm	W/metre 75/65-20	W/metre 90/70-20	W/section 75/65-20	litres/ metre	litres/ section	kg/ metre
300	1177	1504	39.2	7.0	0.23	48.8	1.63
400	1463	1879	48.8	9.8	0.33	64.4	2.15
500	1732	2225	57.7	12.8	0.43	79.5	2.65
600	1994	2562	66.5	15.7	0.52	94.1	3.14
700	2252	2897	75.1	18.5	0.62	108.8	3.63
1000	3018	3890	100.6	27.4	0.91	155.0	5.17

Tapping designation



Plan® single with side tapplings



Plan® double with side tapplings

Fig. 4.2.6
Tapping designation

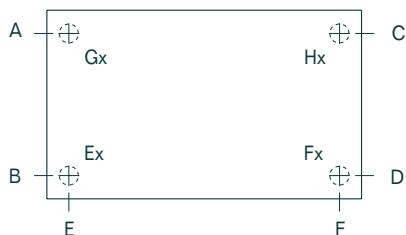
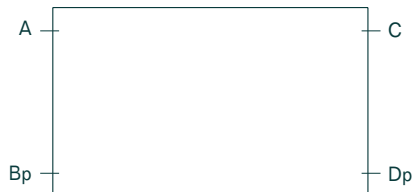

Fig. 4.2.7
Tapping designation, 2E and 2F



NOTE: If flow and return are required at the same end, radiators above a certain length must have forced flow, via a return tube at the bottom rear of the radiator, to prevent a reduction in output. For this purpose tapping positions Bp, Dp are used, see fig. 4.2.8 and page 4.2.4.

Fig. 4.2.8
Tapping designation A, Bp, C, Dp



NOTE: A and C connections alone must not be used for flow and return connections.

- 4.0
- 4.1
- 4.2
- 4.3
- 4.4
- 4.5
- 4.6
- 4.7
- 4.8

Technical specifications

Plan®

Side tappings A, B, C, D

Sizes

1/2" standard, adapter for 3/8" and 3/4"

Position

Fig. 4.2.9
Plan® single, side tappings

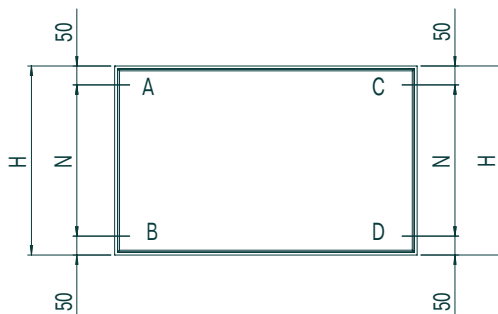

Fig. 4.2.10
Plan® single, profile

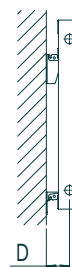

Fig. 4.2.11
Plan® double, side tappings

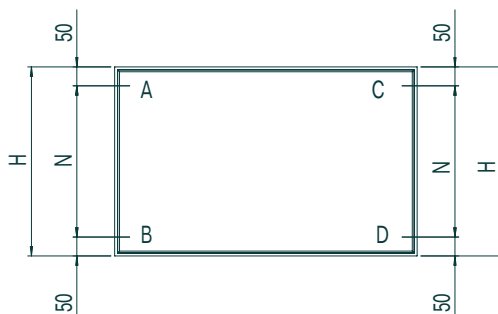

Fig. 4.2.12
Plan® double, profile

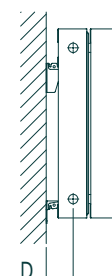

Table 4.2.13
Centre distance N for A, B, C, D tappings

Radiator height H, mm	Centre distance N, mm
300	200
400	300
500	400
600	500
700	600
1000	900

Table 4.2.14
Wall dimension D

Radiator depth, mm	D mm
40	24/44
60	41/61
80	51/71
126	41/61
166	51/71

Forced flow

Plan® single and double

VARIANT

If flow and return are required at the same end of a Plan®, a factory-fitted rear return tube may be required to ensure optimum water flow. This depends on the temperature drop and radiator lengths shown in table 4.2.17. Forced flow is obtained by the rear return tube, through which the water is returned from the opposite side of the radiator. The rear return pipe is supplied with 1/2" tappings.

For return tube at the rear, tapping positions Bp or Dp are used, see figs. 4.2.15 and 4.2.16

NOTE: Minimum wall distance when using return tube is 30 mm

Fig. 4.2.15
Plan® single with rear return tube,
rear view

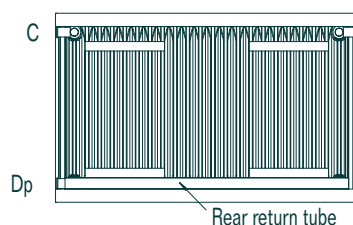

Plan with rear return pipe has same tapping designations as standard AB or CD tappings

Fig. 4.2.16
Plan® single with rear
return tube, profile

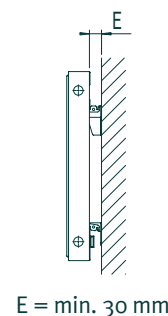

E = min. 30 mm

Table 4.2.17
The maximum length without use of return tube for same end tapping

Radiator height H, mm	Temperature drop ($t_{\text{flow}} - t_{\text{return}}$)		
	10°C	20°C	30°C
300-600	1200	1700	2000
700 & 1000	1400	1800	2000

- 4.0
- 4.1
- 4.2
- 4.3
- 4.4
- 4.5
- 4.6
- 4.7
- 4.8
- 4.2.4

Technical specifications

Plan®

Top and bottom tapings E, F, G, H, 2E, 2F

VARIANT

Sizes

1/2" standard, adapter for 3/8" and 3/4"

Plan® single

Fig. 4.2.18
Plan® single, top and bottom tapings

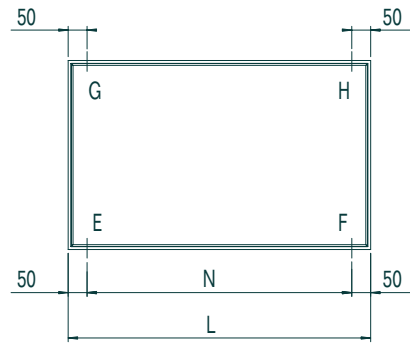
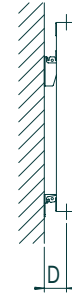

Fig. 4.2.19
Plan® single, top and bottom tapings, profile



Plan® single: centre distance N is calculated as: radiator length L - 100 mm

Plan® double

Fig. 4.2.20
Plan® double, top and bottom tapings

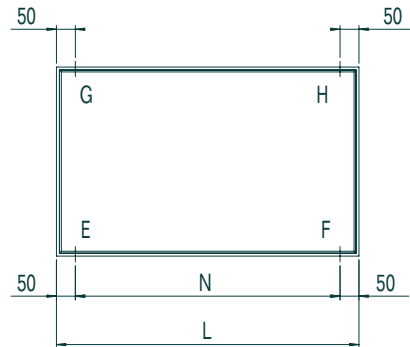
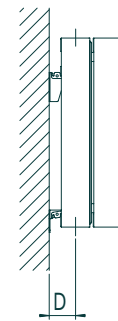

Fig. 4.2.21
Plan® double, top and bottom tapings, profile



Plan® double: centre distance N is calculated as: radiator length L - 100 mm

2E, 2F, Plan® single

Fig. 4.2.22
Plan® single, 2E and 2F tapings

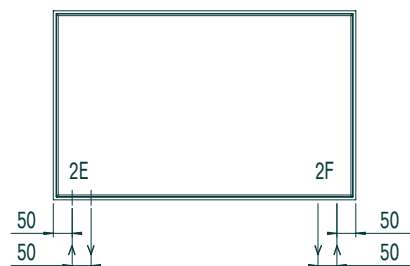
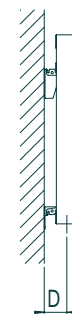

Fig. 4.2.23
Plan® single, 2E and 2F tapings, profile



NOTE: Flow is always placed in the outer tapping

To ensure optimum water flow Plan®, with 2E or 2F tapings, above a certain length must be factory fitted with forced flow using a return tube, see table 4.2.17. Application of return tube at 2E or 2F does not change the tapping position in the radiator.



2E, 2F, Plan® double

Fig. 4.2.24
Plan® double, 2E and 2F tappings

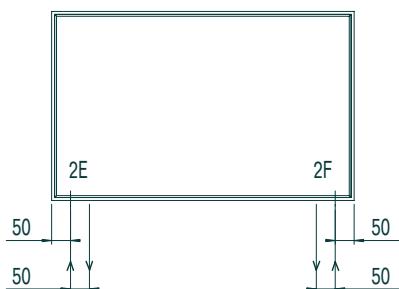

Fig. 4.2.25
Plan® double, 2E and 2F tappings, profile

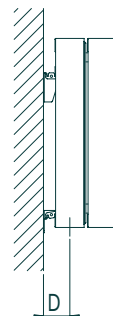

Table 4.2.26
Wall distance at top and bottom tappings

Depth, mm	D, mm
40	24/44
60	41/61
80	51/71
126	41/61
166	51/71

NOTE: Flow is always placed in the outer tapping



4.0



4.1



4.2



4.3



4.4



4.5



4.6



4.7



4.8

Technical specifications

Plan®

Rear tapplings Ex, Fx, Gx, Hx

VARIANT

Sizes

1/2" standard, adapter for 3/8" and 3/4"

Position

Fig. 4.2.27
Rear tapplings

Fig. 4.2.27/A
Rear tapplings, Profile

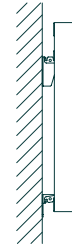
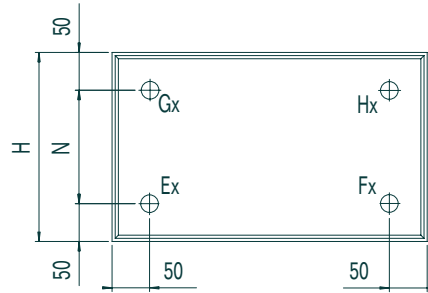

Table 4.2.28
Centre distance N for Gx-Ex and Hx-Fx tapplings

Radiator height H, mm	Centre distance N, mm
300	200
400	300
500	400
600	500
700	600
1000	900

Horizontal centre distance Gx-Hx and Ex-Fx is calculated as:
Radiator length L – 100 mm

For optimum performance we recommend Gx-Fx or Hx-Ex.

Consideration should be given to the positioning of valves, if rear tapplings are ordered: see page 4.4.8 for Model UR-Flex, which conceals pipework and ease the installation.

Water resistance

Maximum expected pressure loss - calculated from the largest possible radiators.

Water temperature - flow	t_f	°C	75	70	70	65	90	55
Water temperature - return	t_r	°C	65	40	55	35	70	45
At Plan® depth 40 mm: H = 1000 mm and L = 4000 mm								
Pressure loss		kPa	2.1	0.1	0.6	0.1	0.7	0.5
At Plan® depth 60 mm: H = 1000 mm and L = 4000 mm								
Pressure loss		kPa	2.6	0.2	0.7	0.1	1.2	0.7
At Plan® depth 80 mm: H = 1000 mm and L = 4000 mm								
Pressure loss		kPa	3.5	0.2	1.2	0.2	1.7	1.2
At Plan® depth 126 mm: H = 1000 mm and L = 4000 mm								
Pressure loss		kPa	6.3	0.3	2.1	0.2	2.8	1.9
At Plan® depth 166 mm: H = 1000 mm and L = 4000 mm								
Pressure loss		kPa	8.4	0.5	3.1	0.3	3.9	2.6
Pressure losses for other heights/lengths can be approximated on a proportional basis								

Bracket BP10/30

Accessory

Plan®. Supplied unless otherwise specified.

Construction

Bracket and spacer in galvanised mild steel with nylon inserts for noise suppression.

Optional wall distance: 10 or 30 mm to rear of radiator.

Dimensions

Fig. 4.3.1
Bracket BP10/30

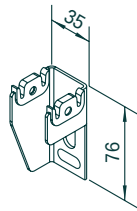

Fig. 4.3.2
Bracket BP10/30

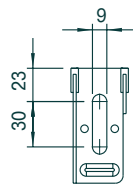
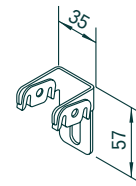

Fig. 4.3.3
Spacer for bracket BP10/30



NOTE: For tamper proof installation the spacer should be fixed to the wall, see page 4.3.2

All radiators are factory fitted with rails for optional positioning of brackets, see figs. 4.3.4 and 4.3.6

Fig. 4.3.4
Plan® single, profile

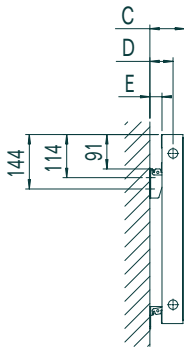

Fig. 4.3.5
Plan® single, profile

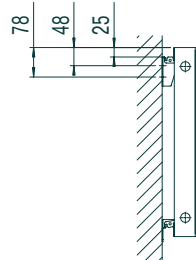

Fig. 4.3.6
Plan® double, profile

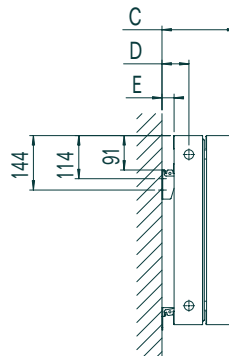

Fig. 4.3.7
Plan® double, profile

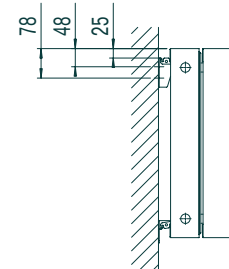
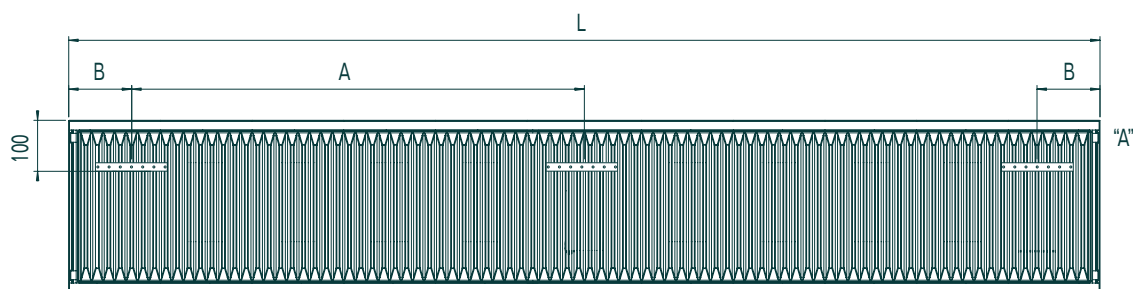

Table 4.3.8
Wall dimensions

Depth, mm	C, mm	D, mm	E, mm
40	50/70	24/44	10/30
60	70/90	41/61	10/30
80	90/110	51/71	10/30
126	136/156	41/61	10/30
166	176/196	51/71	10/30

Fig. 4.3.9
Position of rails, rear view



If no. of brackets is 3 or more and uneven no. of sections, the rail in the middle is displaced 17 mm towards tapping "A".

Table 4.3.10
Plan® single and double, position of rails and no. of brackets

Radiator length L, mm	No. of sections	No. of brackets/ spacers/goal posts	A mm	B mm
400-567	12-20	2/2/1	-	-
600-1667	21-50	2/2/2	L-366	183
1700-2467	51-74	3/3/3	(L-366)/2	183
2500-4000	75-120	4/4/4	(L-366)/3	183

NOTE: Table 4.3.10 applies to all types of brackets.
Radiators shorter than 600 mm have one continuous rail.

Tamper proof installation Spacer can be used for tamper proof installation of radiator, see figs. 4.3.11 - 13

Fig. 4.3.11
Loosely mounted spacer

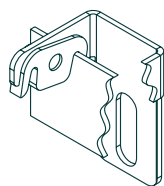

Fig. 4.3.12
Fixed spacer, elevated for fixing

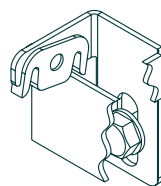
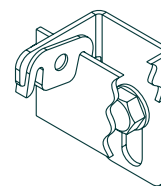

Fig. 4.3.13
Spacer in fixed position



4.0

4.1

4.2

4.3

4.4

4.5

4.6

4.7

4.8

4.3.2

Adjustable brackets BP28-70, BP48-90, BP68-110

VARIANT

Accessory for Plan®

Application For use where variable wall distance is required, or where uneven walls prevent the use of fixed brackets.

Construction Bracket in galvanised mild steel with nylon inserts for noise suppression. Spacer in galvanised mild steel with adjuster screw.

Dimensions

Fig. 4-3.14
Bracket BP28-70,
BP48-90 and BP68-110

Fig. 4-3.15
Bracket BP28-70,
BP48-90 and BP68-110

Fig. 4-3.16
Spacer for bracket
BP28-70, BP48-90
and BP68-110

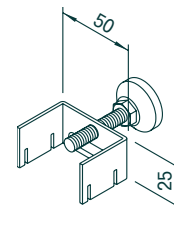
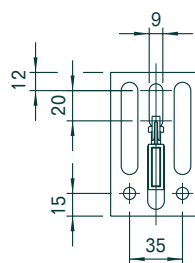
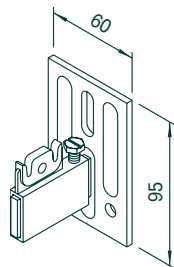

Fig. 4-3.17
Plan® single, profile

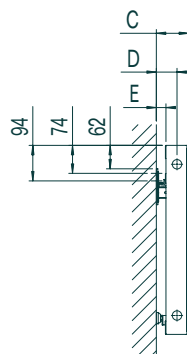
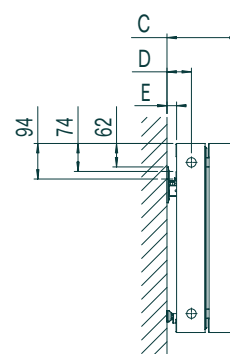

Fig. 4-3.18
Plan® single, profile



4.0



4.1



4.2



4.3



4.4



4.5



4.6



4.7



4.8

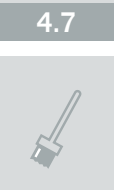
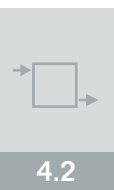
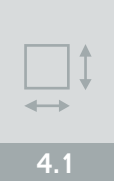

Table 4.3.19
Wall dimensions for bracket BP28-70

Depth	C, mm	D, mm	E, mm
40	68-110	42-84	28-70
60	88-130	59-101	28-70
80	128-150	69-111	28-70
126	156-196	59-101	28-70
166	194-236	69-111	28-70

Table 4.3.20
Wall dimensions for bracket BP48-90

Depth	C, mm	D, mm	E, mm
40	88-130	68-104	48-90
60	108-150	79-121	48-90
80	148-170	89-131	48-90
126	176-216	79-121	48-90
166	214-256	89-131	48-90

Table 4.3.21
Wall dimensions for bracket BP68-110

Depth	C, mm	D, mm	E, mm
40	108-150	88-124	68-110
60	128-170	99-141	68-110
80	168-190	109-151	68-110
126	196-236	99-141	68-110
166	234-276	109-151	68-110

Adjustable feet
PR

VARIANT



Plan® double with feet PR

Accessory for

Plan®

Application

For use where wall mounting is not possible, e.g. in front of glazing.
(cannot be retro-fitted)

Construction

Adjustable feet in 2 mm rectangular steel tube rectangular, welded directly to the 3 mm steel foot plate. Mounted to floor with coach screws

Colour

RAL 9010 (same as radiator)

Dimensions

PR feet, low: 95 - 150 mm, single/double
PR feet, high: 210 - 320 mm, single/double

Fig. 4.3.22

PR feet, low - to Plan® single

PR feet, high - to Plan® single

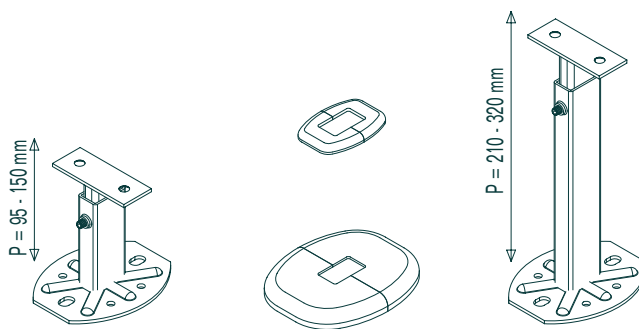
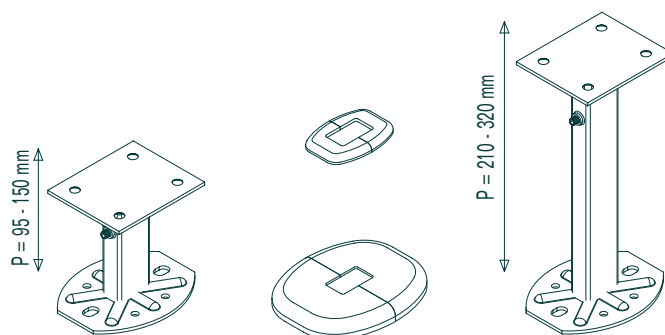

Fig. 4.3.23

PR feet, low - to Plan® double

PR feet, high - to Plan® double



Ordering

Please state: prepared for PR feet. To avoid damage in transit, feet are not delivered attached to the radiator. The feet are supplied complete with bolts for attaching to radiator.



4.0



4.1



4.2



4.3



4.4



4.5



4.6



4.7



4.8

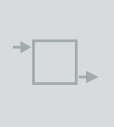
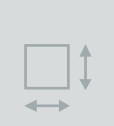

Fig. 4.3.24/A
Plan® single with feet PR,
profile

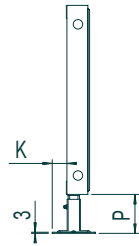

Fig. 4.3.24/B
Plan® double with feet PR
profile

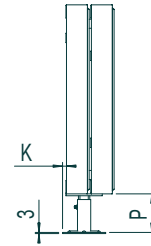
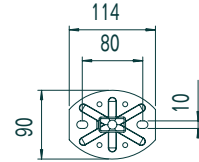

Fig. 4.3.24/C
Foot plate for feet PR,
plan view



NOTE: If rose fitted add 5 mm each side
Smallest wall distance is K + thickness of skirting, see table 4.3.24/D

Table 4.3.24/D
Distance K for foot plate

Depth, mm	K, mm
40	42
60	42
80	42
126	10
166	0

Position and no. of feet

Fig. 4.3.25
Radiator with 2 feet

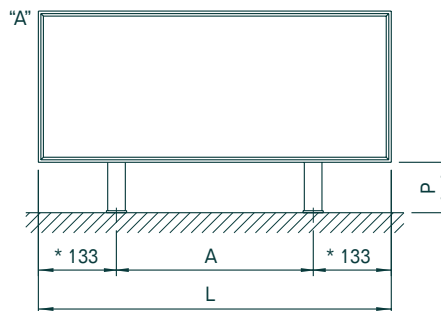
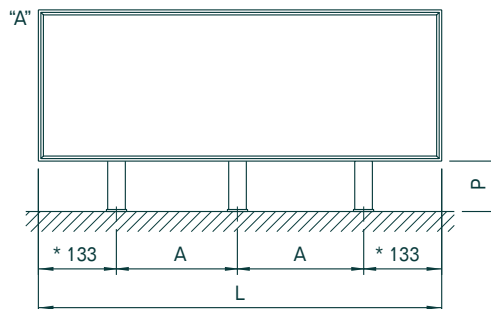

Fig. 4.3.26
Radiator with 3 feet



* Where tappings 2E or 2F are used, dimension 133 mm will change.
Please consult Hudevad.
If no. of feet is 3 the foot in the middle is displaced 17 mm towards tapping "A".

Table 4.3.27
Position and no. of feet

Radiator length L, mm	No. of sections	No. of feet	A mm
400-1800	12-54	2	L-266
1833-2500	55-75	3	L-266/2
2533-4000	76-120	4	L-266/3

NOTE: For radiators above 700 mm from floor to top of radiator, wall brackets should be used as top restraint.



FDC feet **VARIANT**

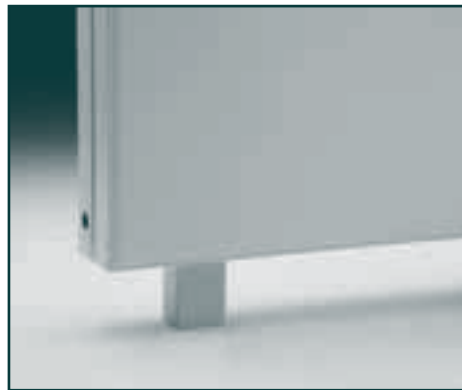

Plan® double with feet FDC

Accessory for

Plan® depths 60, 80, 126 and 166 mm

Application

For use where wall mounting is not possible, e.g. in front of glazing, or combined with underside tappings, where hidden pipework is required.

Construction

Closed rectangular bolted feet in 2 mm steel, with detachable cover. Mounted to floor with coach screws.

NOTE: Allows underside connections to be concealed within foot.

Colour

RAL 9010 (same as radiator)

Dimensions

The FDC foot is available in two widths: 85 mm & 135 mm. These are suitable for opposite end tappings (E,F) and same end tappings (EE/FF) respectively. Height: 100, 120 and 150 mm.

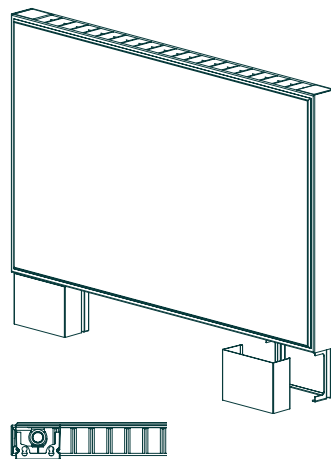

Ordering

NOTE: Please state: “prepared for FDC feet”

NOTE: For radiators above 700 mm from floor to top of radiator, wall brackets should be used as top restraint.

To avoid damage in transit, feet are not delivered attached to the radiator. The feet are supplied complete with bolts for attaching to radiator.



4.0



4.1



4.2



4.3



4.4



4.5



4.6



4.7



4.8

Console feet
FH3-FH7 & FH10

VARIANT



Plan® double with console feet FH

Accessory for

Plan®

Application

For use where wall mounting is not possible. The foot plate can be fixed through a raised floor or embedded in a concrete floor. Console feet allow the radiator to be adjusted in height.

Colour

Upright and foot plate: Ral 9010 (Same as radiator)
Adjustable collars: Galvanised

Dimensions

Fig. 4.3.28
Plan® single with
console feet FH,
profile

Fig. 4.3.29
Plan® double with
console feet FH,
profile

Fig. 4.3.30
Foot plate for console feet
FH, plan view

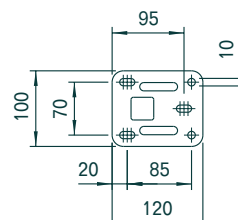
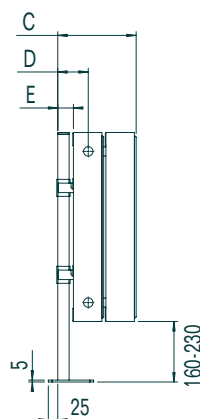
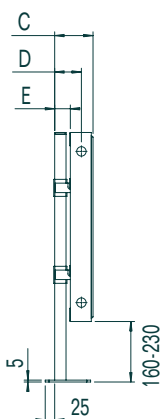

NOTE: If greater or lesser height from floor is required, taller or shorter feet FH can be selected, e.g. FH4 for radiator height 500 mm

Table 4.3.31
Dimensions

Depth	C, mm	D, mm	E, mm
40	82	55	42
60	102	74	42
80	122	84	42
126	168	74	42
166	208	84	42



Position of rails / goal posts

See page 4.3.2

No. of feet and type

Table 4.3.32
No of feet FH

Radiator length L, mm	No. of sections	No. of feet
400-667	12-18	2
700-1667	21-48	2
1700-2467	51-72	3
2500-4000	75-120	4

Table 4.3.33
Type of feet FH

Radiator height H, mm	Height of feet mm	Type of feet
300	460	FH3
400	560	FH4
500	660	FH5
600	760	FH6
700	860	FH7
1000	1160	FH10

NOTE: For radiators above 700 mm from floor to top of radiator, wall brackets should be used as top restraint.



4.0



4.1



4.2



4.3



4.4



4.5



4.6



4.7



4.8

Built-in valve

Plan®

Built-in valve

VARIANT

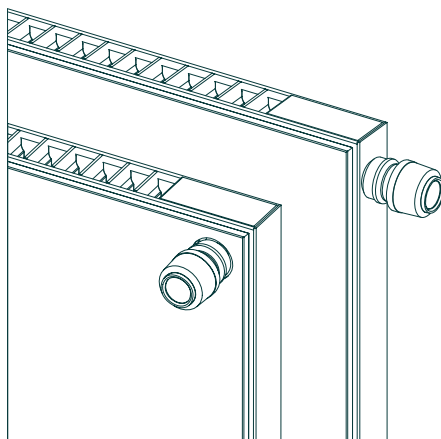

Plan® single with built-in valve Format 1 (front) and Format 3 (side)

Application

For use where a thermostatic valve is to be integrated within the radiator, where discreet pipework is required or for ease of installation. The Format 1 built-in valve occupies 3 sections of water filled ribs. This should be taken in consideration when sizing radiators.

Construction

The built-in valve consists of an extended front plate where there are no water filled sections. The integrated valve and associated pipework is fitted behind the extended front plate, with closed top.

The sensor head projects through a hole in the front plate (Format 1) or the end of the radiator (Format 3). A special integrated valve with pre-setting for limiting the maximum water flow is used.

There are several valve heads available to suit the following 2 valve body options:

1: Danfoss RA-N integrated valve body to suit Danfoss heads having click-on coupling.

2: Danfoss type RA-N Integrated valve body, with M30 x 1.5 mm connection thread adapter, to suit Oventrop, Heimeier, MNG, Drayton and Honeywell sensors.

NOTE: Danfoss sensor head RA 2990 is supplied unless otherwise stated (option 1).

Dimension

As shown on Fig. 4.1.1, page 4.1.3, except Format 1: minimum length 500 mm

Tappings

Formats 1 and 3 have bottom 1/2" tappings;

Combinations 2E, 2F or E-F can be ordered. The air vent is opposite the valve. UR-flex tappings are available for concealed pipework, see pages 4.4.8 - 10.

NOTE: To ensure optimum water flow Plan®, with 2E or 2F tappings, above a certain length must be factory fitted with forced flow using a return tube, see page 4.2.4. Application of return tube at 2E or 2F does not change the tapping position in the radiator.

Position of mounting rails

The position of the mounting rails follow the same principles as for radiators without built-in valve, with the exception that measurement B on Fig. 4.3.9, page 4.3.2 is 250 mm on the valve side.

Format 1

Sensor head through front plate and 1/2" bottom tappings

VARIANT

Fig. 4.4.1.
Plan® single and double, built-in valve Format 1

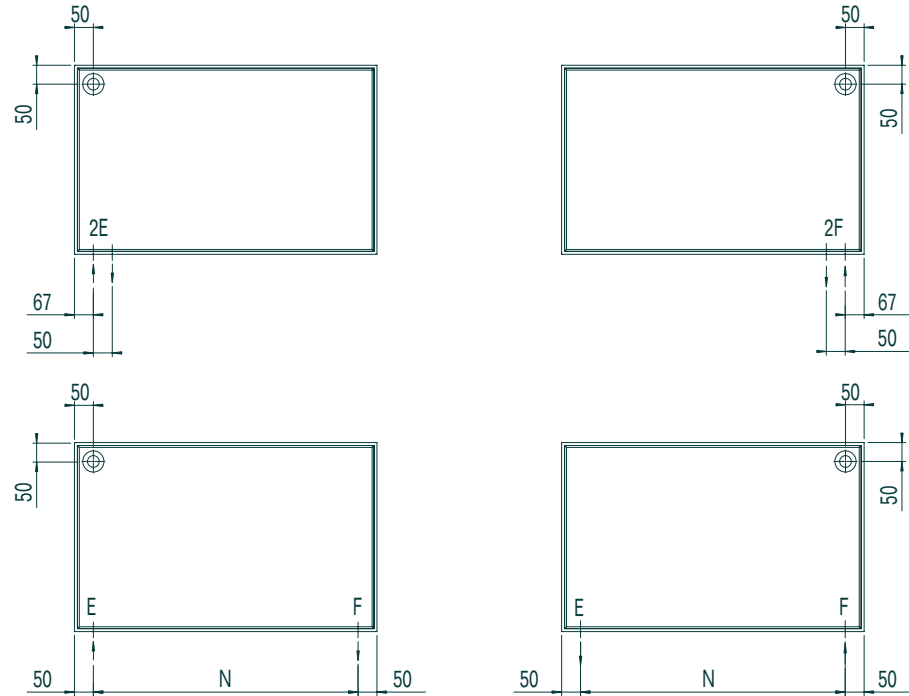

Centre distance N is calculated as: Radiator length - 100 mm

Fig. 4.4.2
Plan® single, built-in valve Format 1,
plan view

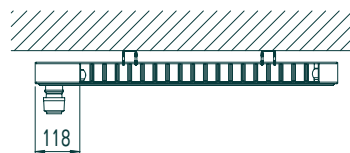
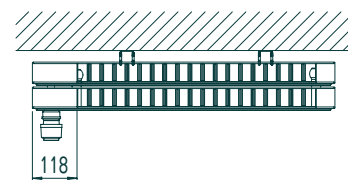

Fig. 4.4.3
Plan® double, built-in valve Format 1,
plan view



- 1 —
- 2 —
- 4.0
- 4.1
- 4.2
- 4.3
- 4.4
- 4.5
- 4.6
- 4.7
- 4.8

Built-in valve

Plan®

Dimensions

Fig. 4.4.4
Plan® single, built-in valve
format 1, profile

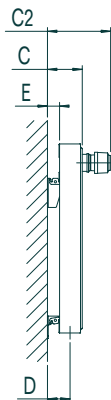

Fig. 4.4.5
Plan® double, built-in valve
format 1, profile

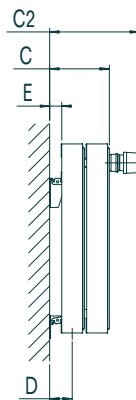

Table 4.4.6
Format 1, wall dimensions

Depth	C, mm	C2, mm	D, mm	E, mm
40	70	146	44	30
60	90	166	61	30
80	110	186	71	30
126	156	232	61	30
166	196	272	71	30

NOTE: C2 measurement is for Danfoss sensor head RA 2990

Format 3

Side facing sensor head and 1/2" bottom tappings **VARIANT**

Fig. 4-4-7.
Plan® single and double, built-in valve Format 3

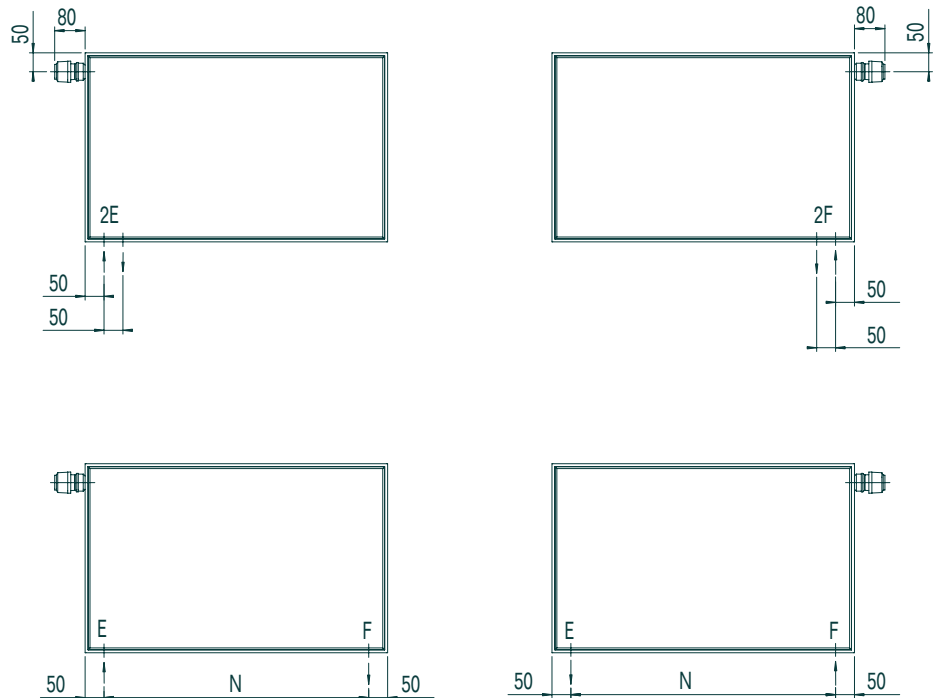

Centre distance N is calculated as: Radiator length - 100

NOTE: Measurement is for Danfoss sensor head RA 2990

Fig. 4-4-8
Plan® single, built-in valve Format 3,
plan view

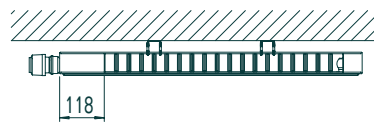
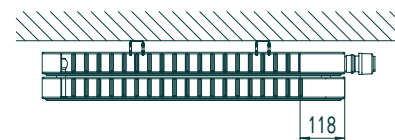

Fig. 4-4-9
Plan® double, built-in valve Format 3,
plan view



Built-in valve

Plan®

Fig. 4.4.10
Plan® single, built-in valve
format 3, profile

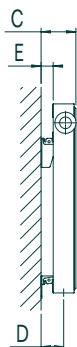

Fig. 4.4.11
Plan® double, built-in valve
format 3, profile

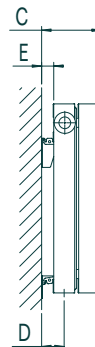

Table 4.4.12
Format 3, wall dimensions

Depth	C, mm	D, mm	E, mm
40	70	44	30
60	90	61	30
80	110	71	30
126	156	61	30
166	196	71	30

NOTE: Minimum wall distance is 30 mm

Ordering

When ordering please state total radiator length including built-in valve. Please also state built-in valve format, type of sensor connections, position of valve - left or right hand - and the tapping requirements.

Example: Plan® 500/40-2000, Format 1, Danfoss, left, 1/2" E & F

Format 4

Built-in valve concealed behind the radiator front plate for remote sensor/adjuster or motorised valve. Please consult Hudevad

INDIVIDUAL

2E/2F, Format 1
Fig. 4.4.13

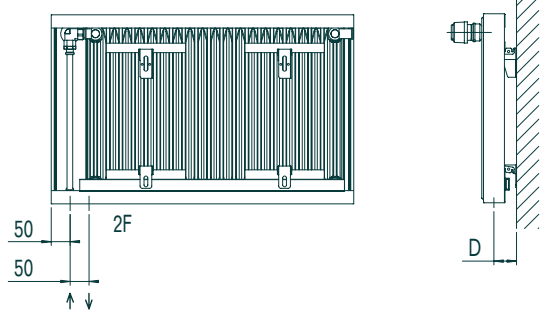
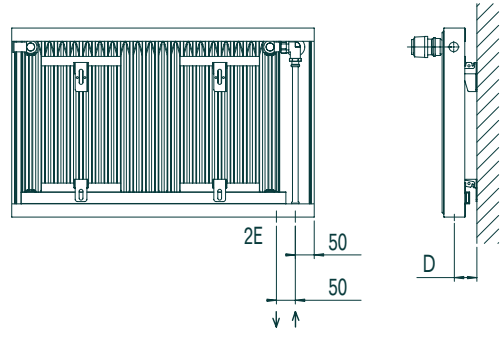

2E/2F, Format 3
Fig. 4.4.14

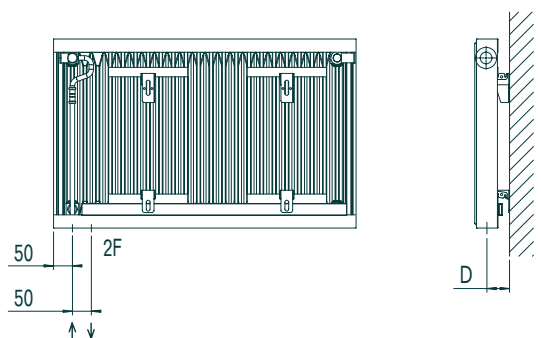
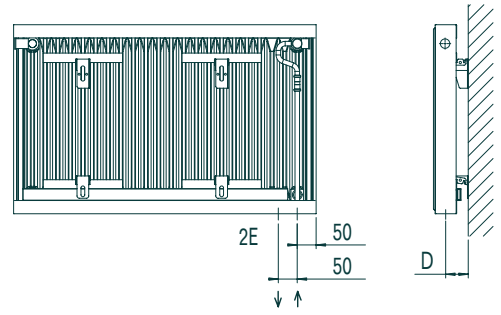

4.0



4.1

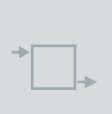

4.2



4.3



4.4



4.5



4.6



4.7



4.8

Built-in valve

Plan®

EF/FE, Format 1

Fig. 4.4.15

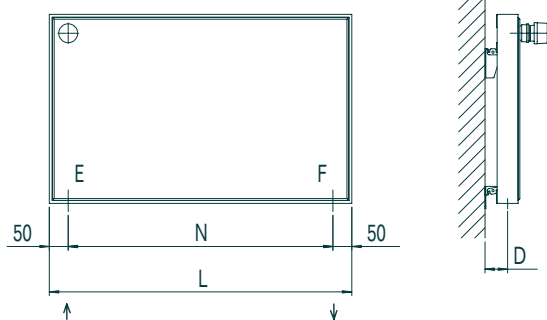
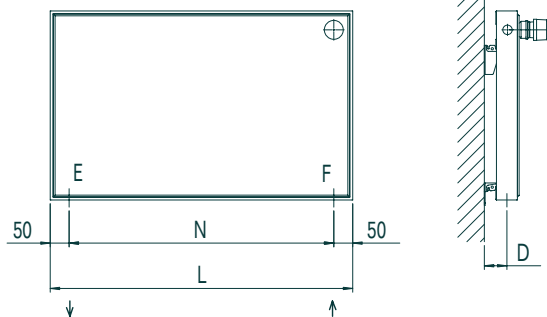

EF/FE, Format 3

Fig. 4.4.16

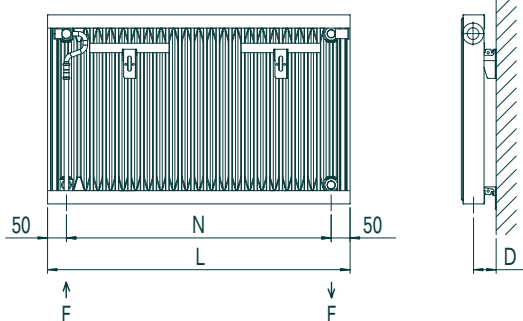
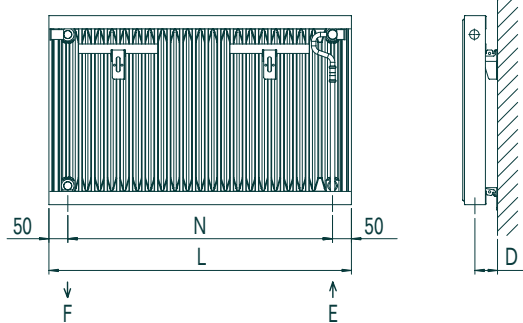

4.0

4.1

4.2

4.3

4.4

4.5

4.6

4.7

4.8

4.4.7



Model UR-flex

Description Model UR-flex embraces a simple, timeless design through a unique connection method that conceals all pipework.

Application For use where concealed pipe work is required, or for the ease of installation.
NOTE: Can also be combined with built-in valve

Construction Tappings and the UR-flex hoses are concealed behind extended front plate. Only air vent and, if required, built-in valve is visible on the front. Flexible hoses are made of temperature resistant plastic material.

Tappings The radiators can be supplied for opposite end or same end connections. If same end connections are required, the recommended max length should be observed; see table 4.4.17

Table 4.4.17

Radiator- height H, mm	Temperature drop ($t_{\text{flow}} - t_{\text{return}}$)		
	10°C	20°C	30°C
300-600	1200	1700	2000
700 & 1000	1400	1800	2000

For longer radiators, diagonal tappings A-D or C-B are required.

NOTE: UR-flex is not available with rear return tube.

NOTE: UR-flex is not available with Format 3 on Plan® 40

NOTE: UR-flex with built-in thermostatic valve does not isolate the radiator, additional isolation and lockshield valves are still required.

UR 1 - 8 flex hoses all have 1/2" tappings.

Mounting The UR-flex hoses, provided by Hudevad, are fitted between the concealed radiator tappings and the installer's pipework. The radiator can then be mounted back on the brackets.

NOTE: This makes UR-flex easier to install than direct rear facing tappings; (X-tappings).

Ordering When ordering please state total radiator length. Please also state UR model and if built-in valve is required.

Example:

Plan®, height 600 mm, depth 60 mm, length 2000 mm, format 1 built-in valve left, A & D tappings.

Please state:

Plan® 600/60-2000 UR2 (see page 4.4.9).



4.0



4.1



4.2



4.3



4.4



4.5



4.6



4.7



4.8

Format 1

Model references and suggested dimensions for concealed pipework connections within wall.

NOTE: Upper circle denotes suggested location for concealed flow pipework connection in wall. Lower circle denotes suggested location for return. (Fig. 4.4.18 - 25).

Fig. 4.4.18

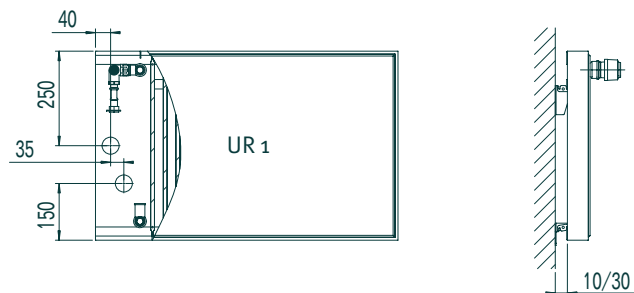

Fig. 4.4.19

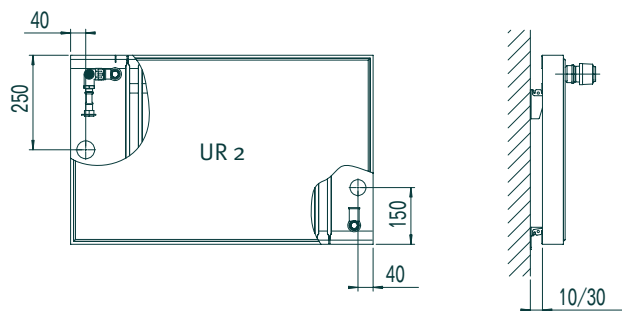

Fig. 4.4.20

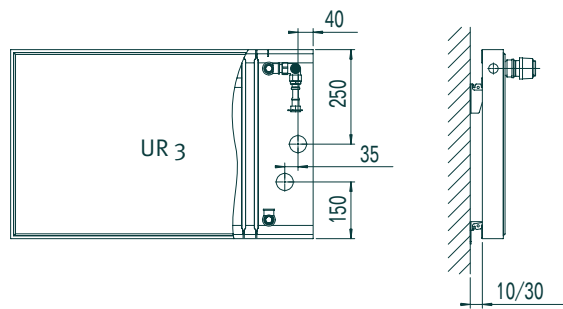
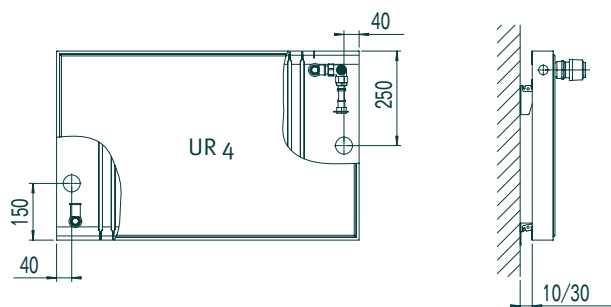

Fig. 4.4.21





Format 3
Fig. 4.4.22

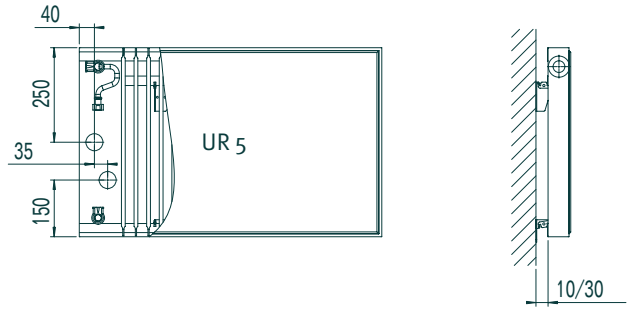

Fig. 4.4.23

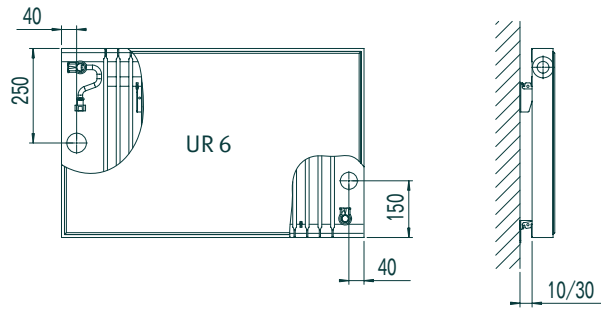

Fig. 4.4.24

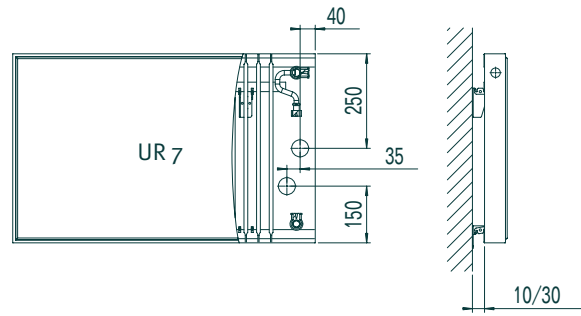
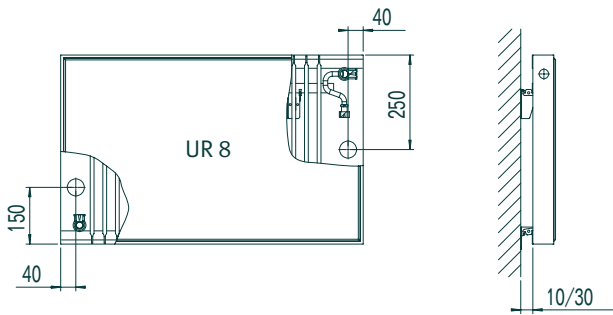

Fig. 4.4.25



4.0



4.1

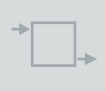

4.2



4.3



4.4



4.5



4.6



4.7



4.8

Angled and curved radiators

Plan®

Angled radiators

INDIVIDUAL

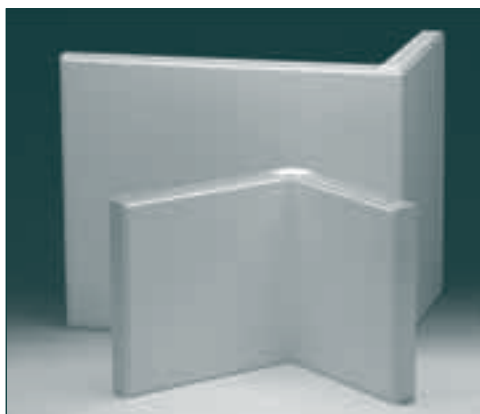

Plan® single angled

Description

All Plan® single radiators can be supplied angled. Tapping designations and maximum dimensions follow the same principles as for straight radiators.

- Min. internal angle V : 45°
- Max. external angle V : 270°
- Max. 4 angles per radiator
- Max. weight: 250 kg

Built-in valve

See page 4.4.1

NOTE: Min. length of side where valve is to be built-in: 300 mm (= 9 sections)

Fig. 4.5.1
External angle

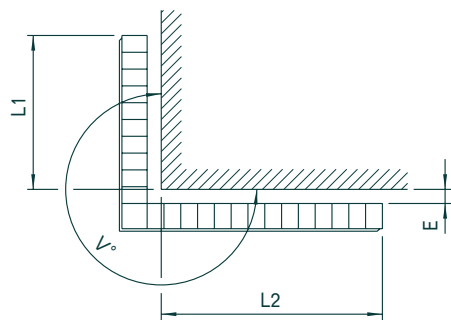

Fig. 4.5.2
Internal angle

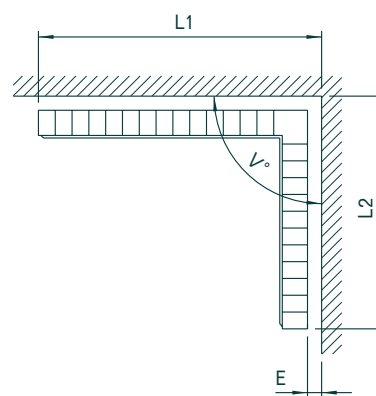
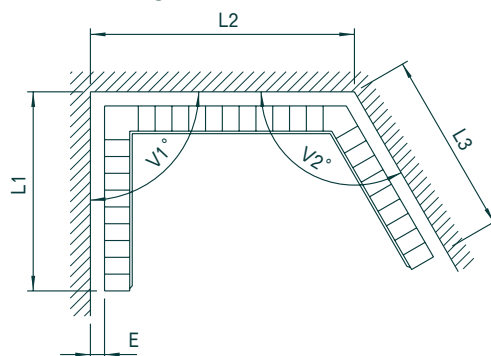

Fig. 4.5.3
2 internal angles





Ordering

Please state:

- The wall measurements L1, L2 etc. in mm
- Angle V with 0,1° accuracy
- The wall distance E in mm (min. 30 mm recommended)
- Clear reference to project (project no. or order no., pos./ref.no. etc.)

NOTE: It is essential to base all dimensions on finished wall surfaces



4.0

Template

Alternatively a rigid template (not made from paper or cardboard) should be made to the finished surface of the wall. Please indicate the following on the upper surface of the template:

- E (wall distance)
- Start and finish point of radiator
- Clear indication of radiator and wall position
- Radiator model (Plan® 40, Plan® 60, Plan® 80)
- Clear reference to project (project no. or order no., pos./ref. no. etc.)



4.1

Output calculation

When calculating the radiator output the length of the front plate and not the length of the wall must be used



4.2

Mounting

Wall or floor mounted, see pages 4.3.1 - 9

NOTE: Unless otherwise specified the radiator is supplied with bracket BP28/70, wall distance 30 mm, see page 4.3.3. If other wall distance is required, please consult Hudevad, at the time of ordering.

NOTE: No. of brackets or feet will be individually determined by Hudevad



4.3

Tolerances

Angled radiators are manufactured individually. The length of each radiator limb can deviate by $\pm 1/2$ section (± 17 mm) from the indicated wall measurements L1, L2 etc.



4.4



4.5



4.6



4.7



4.8

Angled and curved radiators

Plan®

Curved radiators

INDIVIDUAL

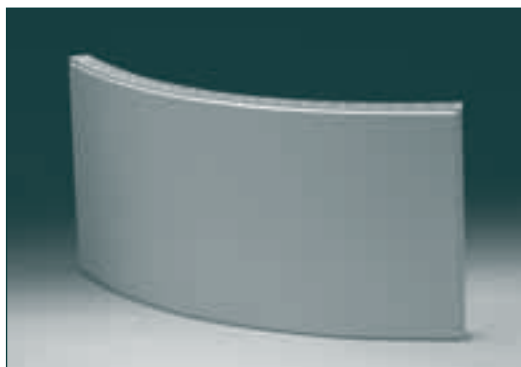

Plan® single curved

Description

All Plan® single radiators can be supplied curved. Tapping designations and maximum dimensions follow the same principles as for straight radiators.

Min. radius: 600 mm

Max. weight: 250 kg

Fig. 4.5.4
Internal curve

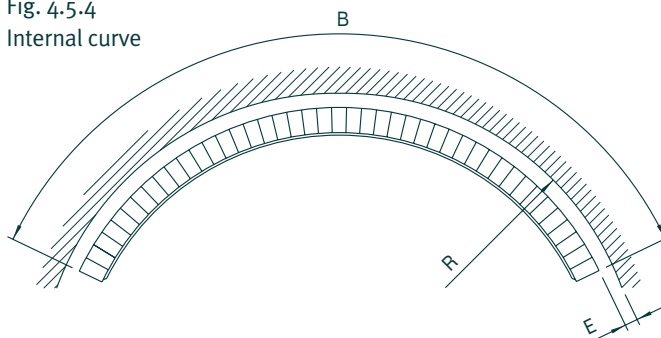
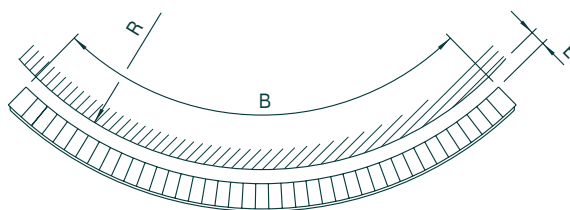

Fig. 4.5.5
External curve





Ordering

Please state:

- Wall distance B in mm
- Wall radius in mm
- Wall distance E in mm (min. 30 mm recommended)
- Clear reference to project (project no. or order no., pos./ref.no. etc.)

NOTE: It is essential to base all dimensions on finished wall surfaces



4.0

Template

Alternatively a rigid template (not made from paper or cardboard) should be made to the finished surface of the wall. Please indicate the following on the upper surface of the template:

- E (wall distance)
- Start and finish point of radiator
- Clear indication of radiator and wall position
- Radiator model (Plan® 40, Plan® 60, Plan® 80)
- Clear reference to project (project no. or order no., pos./ref. no. etc.)



4.1

Output calculation

When calculating the radiator output the length of the front plate and not the length of the wall must be used



4.2

Mounting

Wall or floor mounted, see pages 4.3.1 - 9

NOTE: Unless otherwise specified the radiator is supplied with adjustable bracket BP28-70, wall distance 30 mm, see page 4.3.3. If other wall distance is required, please consult Hudevad, at the time of ordering.



4.3

NOTE: No. of brackets or feet will be individually determined by Hudevad



4.4



4.5



4.6



4.7



4.8

Accessories

Plan®

Plan® back plate **VARIANT**

Accessory for Plan®

Application For use where rear of radiator is visible, e.g. in front of glazing.

Construction 2 mm rebated steel plate, welded on rear of radiator.

Dimensions Length: 400 - 4000 mm (12 - 120 sections)
Radiator depth increased by 5 mm

NOTE: If Plan® back plate is required the radiator must be ordered mounted on feet. Please consult Hudevad regarding restrictions to tapping positions.

Colour Same as radiator

Shelf bracket FSV and anchor piece ASV **VARIANT**

Accessory for Plan®

Application Is combined with console feet FH as a shelf support or mounted directly on radiator using anchor piece ASV.

Construction 10 x 40 mm steel tube with plastic end plugs on 35 x 35 mm steel tube that fits console feet FH. Adjustable height. Secured with steel bolt to the rear.

Colour Galvanised steel

Dimension Fig. 4.6.1
Shelf bracket FSV, mounted on console feet FH

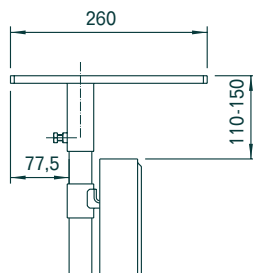
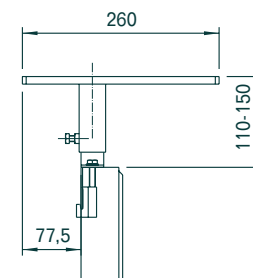
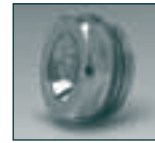

Fig. 4.6.2
Shelf bracket FSV, mounted on Plan® single using anchor piece





Air vent with O-ring 1/2" supplied unless otherwise stated.



4.0

Air vent with O-ring and revolving spout 1/2"



4.1

Plug with O-ring 1/2"



4.2

Square key for air vents



4.3

Sensor head Danfoss sensor head RA 2990 is supplied with built-in valve, unless otherwise stated.



4.4

Expansion bolt with bracket Height adjustable. Bolt depth 150 mm



4.5

Lifting handle For easy handling of Plan® radiators



4.6



4.7



4.8

Standard specification clauses

Plan®

Plan®

“Hudevad radiator, model Plan®, with smooth, flat 2.00 mm thick rebated front plate with closed ends, and 1.25 mm rear plate with pressed steel vertical waterways. Water filled ribs welded on rear plate. Water circulates directly behind the front plate and in the ribs. No detachable clip-ons or covers. Painted with oven dried powder coat or wet coat.

Surface treatment in accordance with DIN 55900 and EN 442.

Test and operating pressure 10 bar/7.7 bar.”

Adjustable bracket BP (page 4-3-3)

“Wall mounted on adjustable brackets with nylon inserts for noise suppression and adjustable spacers.”

Adjustable feet PR (page 4-3-5)

“Adjustable feet in 2 mm rectangular steel tube rectangular, welded directly to the 3 mm steel foot plate. Painted same colour as radiator. Mounted with coach screws.”

Feet FDC (page 4-3-7)

“Closed rectangular feet in 2 mm steel, with detachable cover concealing pipework, in radiator colour.”

Console feet FH (page 4-3-8)

“Console feet type FH, from steel tube (30 x 30 mm, 3 mm square) with height adjustable collar and 5 mm foot plate, in radiator colour.”

Built-in valve (page 4-4.1)

Format 1: “Built-in valve format 1 with sensor head through front plate and bottom tappings.”

Format 3: “Built-in valve format 3 with sensor head through end and bottom tappings.”

Format 4: “Built-in valve hidden behind back plate of radiator and bottom tappings.”

Plan® back plate (page 4-6.1)

“Supplied with Plan® back plate in same appearance as radiator front.”

Shelf bracket FSV and anchor piece ASV (page 4-6.1)

“Shelf bracket FSV mounted on console feet FH as support for shelf. Anchor piece ASV can be fixed directly on the radiator as bracket for shelf bracket FSV.”

Order guide

When stating the size and type of radiator, please use the following format: Model height / depth - length. All measurements are to be stated in mm.

Plan® 500/60 - 2000 1/2” A, 1/2” B, 1/2” C

Please state flow and return position



Maintenance

Painting of primed radiators

Paint suitable for steel surfaces should be used

Repair of powder or wet coated radiators

Water based acrylic paint obtained from a decorating wholesaler can be used.

Recoating of powder or wet coated radiators

After cleaning, powder or wet coated radiators can be recoated with the following:

Powder coat: PE powder

Wet coat: Synthetic, non yellowing coat. Water based or similar acrylic paint.

Hardening: 180°C curing temperature for 10 min.

Packaging

Packaging can be left on the radiators for protection against damage etc. during fitting and re-decoration, but the flow temperature should not exceed 70°C.

Venting

Venting of the radiators is required at commissioning, or if the heating system has been drained. It is recommended that radiators are vented, using a cloth to prevent splashing, when the system is cold and the pump is off.

Cleaning

Light household cleaning materials can be used for painted surfaces. Abrasive materials such as scouring powder should not be used. The rear of the radiator can be cleaned with a soft brush, if necessary, together with a vacuum cleaner.



4.0



4.1



4.2



4.3



4.4



4.5



4.6



4.7



4.8

